

Single Hung Side Load - 3 1/4" W/O Screen Track



Series: 2000

Manufacturing Code: 2001

Drawing 1/2 Scale - For Custom Size Drawing Contact Graham

Note: Sealant Not Shown On Details. Refer To General Installation Instructions.

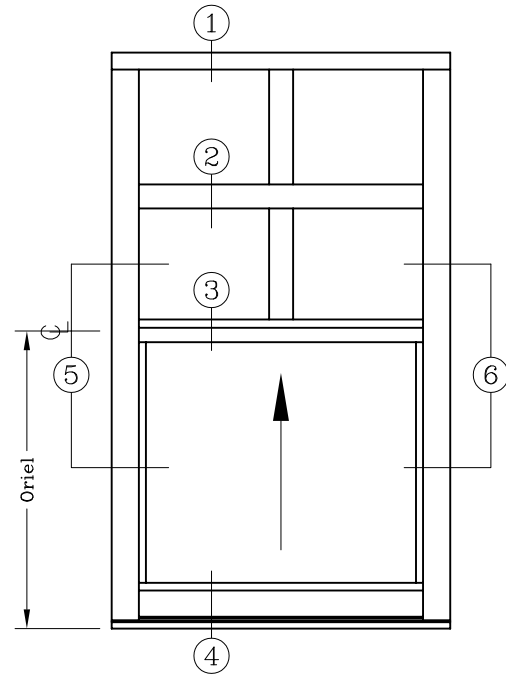
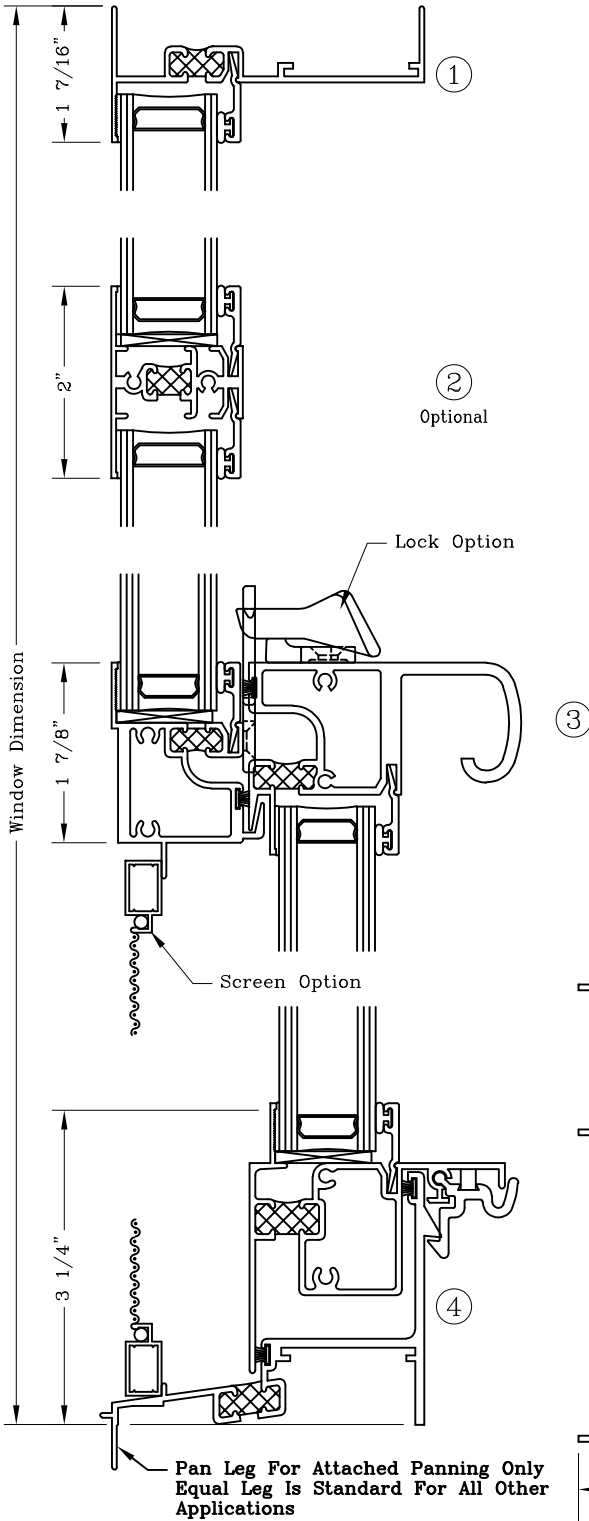

ELEVATION

Optional True Muntin Available For Fixed Lite And Operable Sash

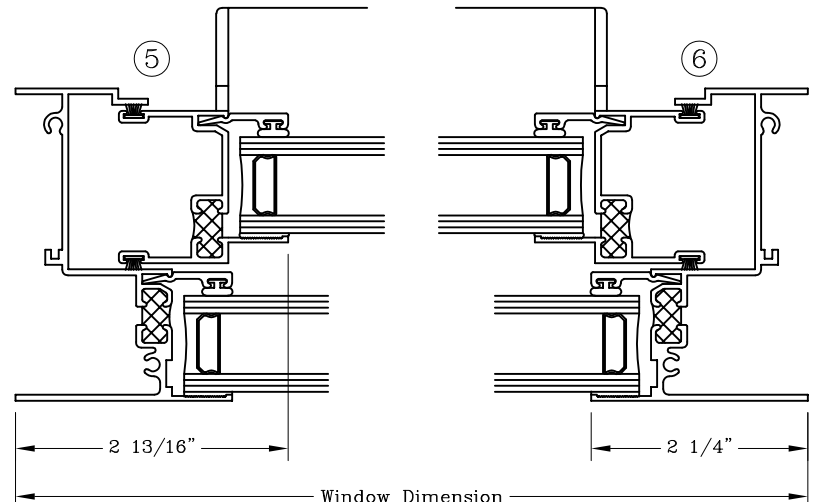
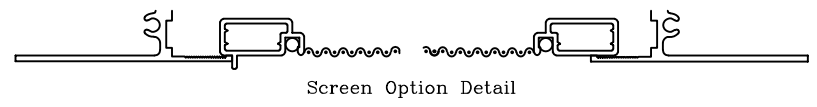

Single Hung Side Load - 3 1/4"
 W/ Screen Track
 Nail Fin



Series: 2000

Manufacturing Code: 2002

Drawing 1/2 Scale - For Custom Size Drawing Contact Graham

Note: Sealant Not Shown On Details. Refer To General Installation Instructions.

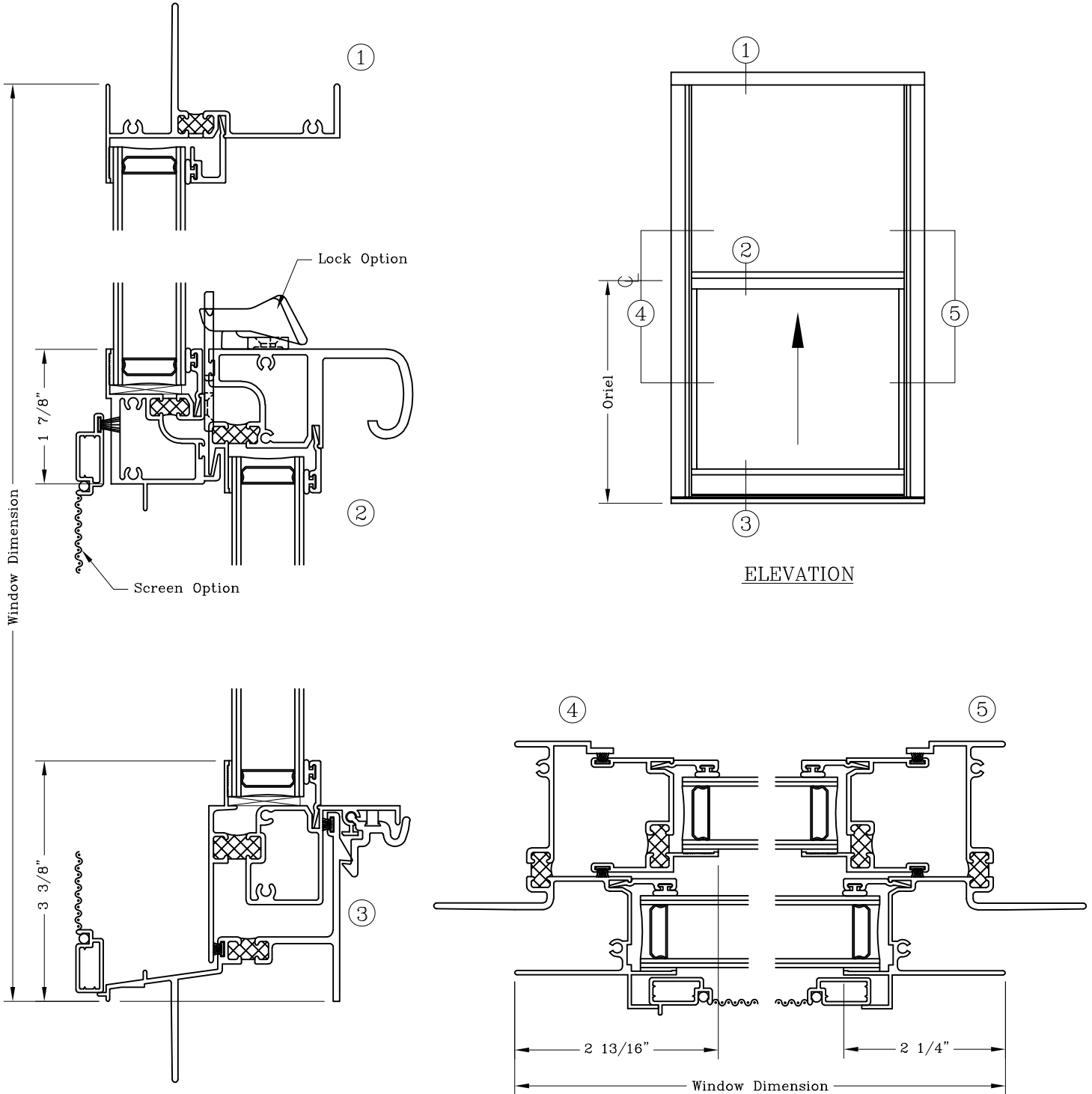

Graham Architectural Products reserves the right to change, add, cancel, remove or otherwise modify the details illustrated without prior notice.

1551 Mt. Rose Avenue, York, Pennsylvania 17403-2909 717.849.8100 Toll Free: 800/755-6274

Web Site: www.grahamwindows.com

0223 - 20.02

Single Hung Side Load – 3 1/4” With Full Screen Track Frame



Series: 2000

Manufacturing Code: 2005

Drawing 1/2 Scale – For Custom Size Drawing Contact Graham

Note: Sealant Not Shown On Details. Refer To General Installation Instructions.

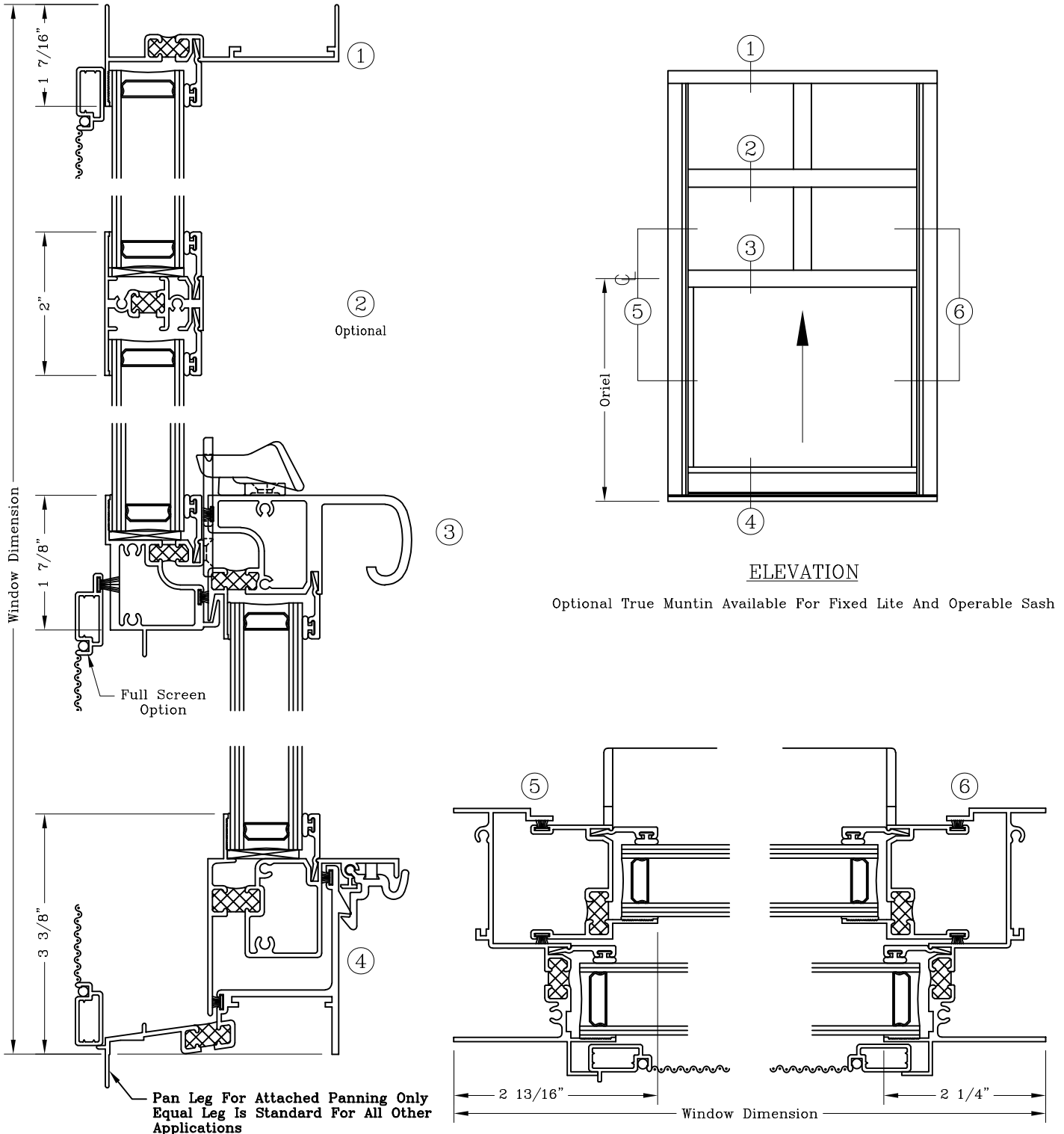

Graham Architectural Products reserves the right to change, add, cancel, remove or otherwise modify the details illustrated without prior notice.

1551 Mt. Rose Avenue, York, Pennsylvania 17403-2909 717.849.8100 Toll Free: 800/755-6274

0223 – 20.05

Web Site: www.grahamwindows.com

Single Hung Over Fixed - 3 1/4"



Nail Fin

Series: 2000H

Manufacturing Code: 2007

Drawing 1/2 Scale - For Custom Size Drawing Contact Graham

Note: Sealant Not Shown On Details. Refer To General Installation Instructions.

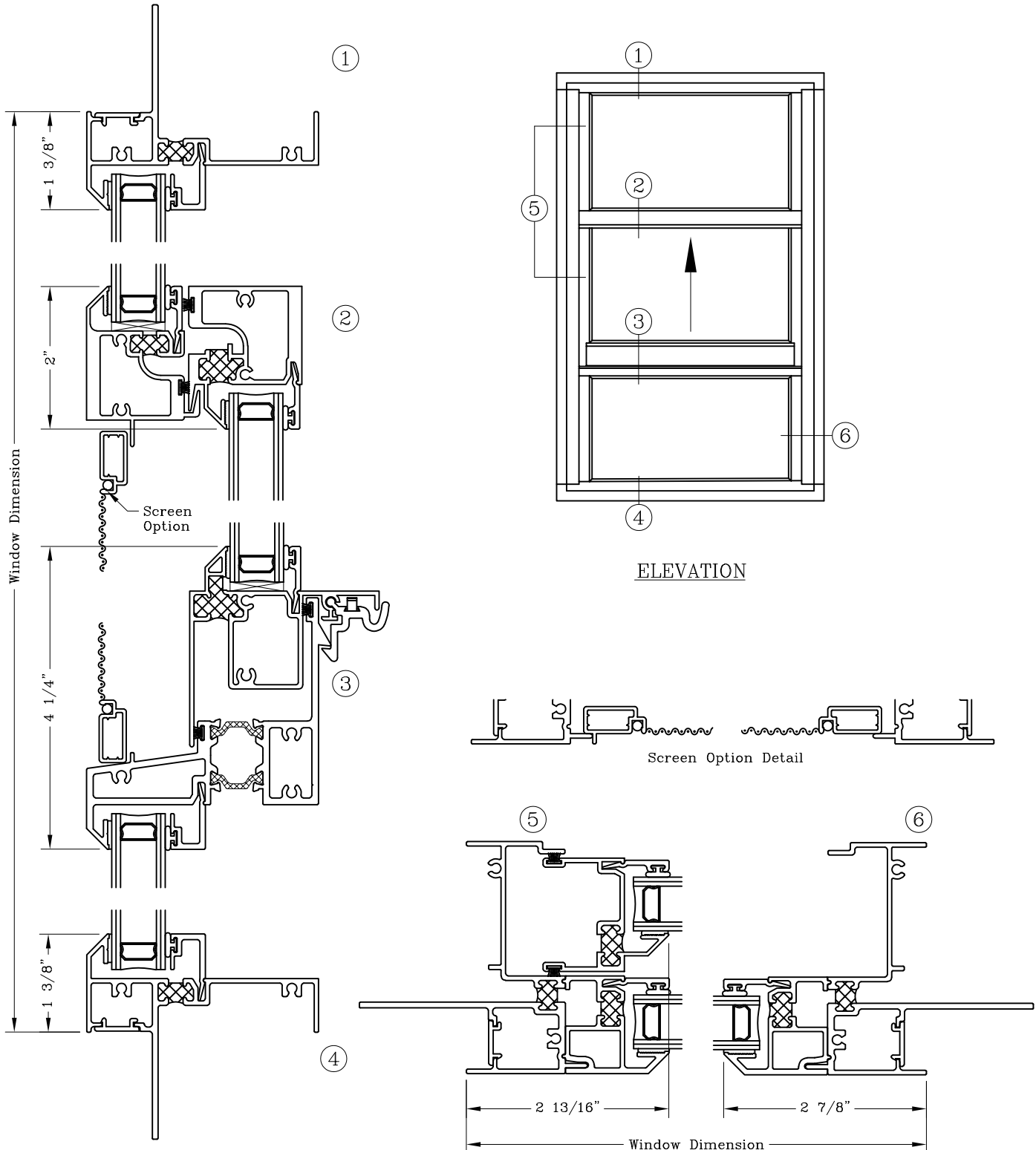

Graham Architectural Products reserves the right to change, add, cancel, remove or otherwise modify the details illustrated without prior notice.

1551 Mt. Rose Avenue, York, Pennsylvania 17403-2909 717.849.8100 Toll Free: 800/755-6274

0223 - 20.07

Web Site: www.grahamwindows.com

Single Hung Side Load 3 1/4" Historic Beveled Frame And Sash Egress



Series: 2000H

Manufacturing Code: 2008

Drawing 1/2 Scale - For Custom Size Drawing Contact Graham

Note: Sealant Not Shown On Details. Refer To General Installation Instructions.

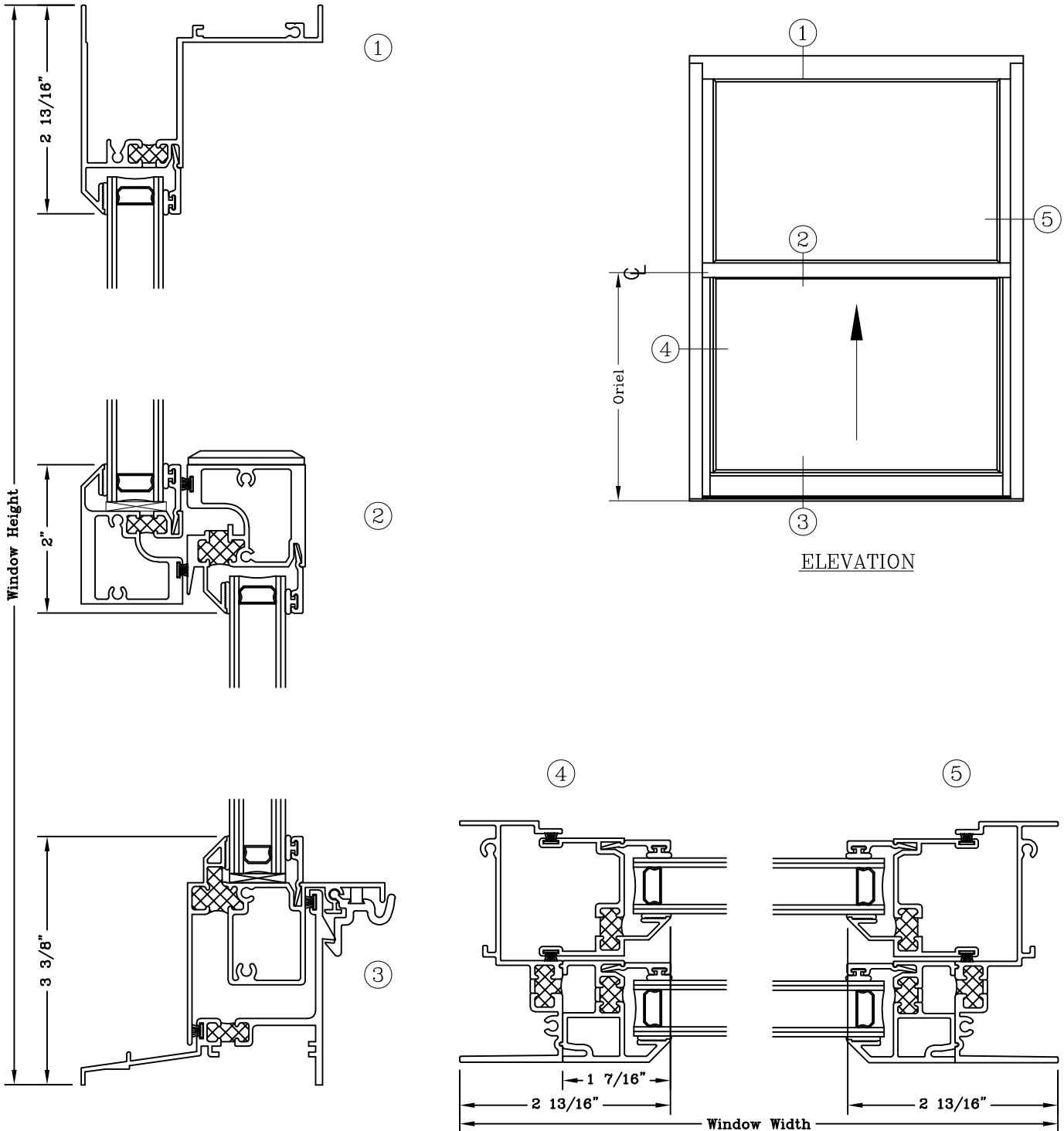

Graham Architectural Products reserves the right to change, add, cancel, remove or otherwise modify the details illustrated without prior notice.

1551 Mt. Rose Avenue, York, Pennsylvania 17403-2909 717.849.8100 Toll Free: 800/755-6274

Web Site: www.grahamwindows.com

0223 - 20.08

Single Hung Side Load 3 1/4" Historic Beveled Frame And Sash



Series: 2000H

Manufacturing Code: 2009

Drawing 1/2 Scale - For Custom Size Drawing Contact Graham

Note: Sealant Not Shown On Details. Refer To General Installation Instructions.

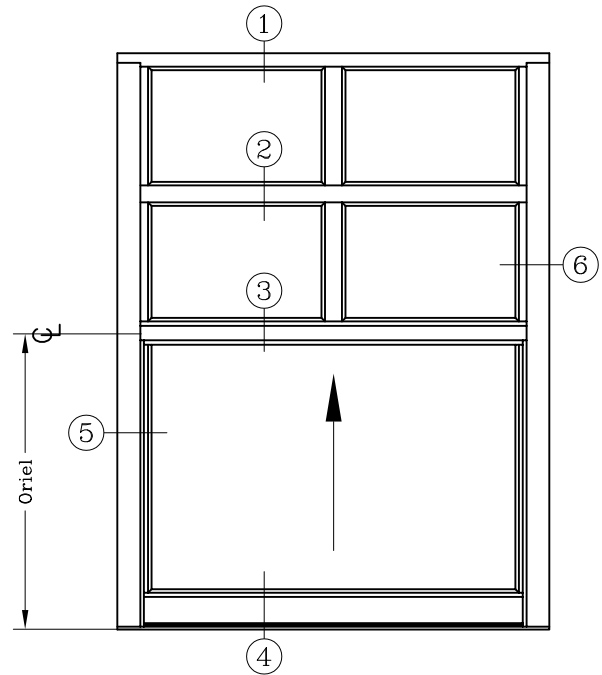
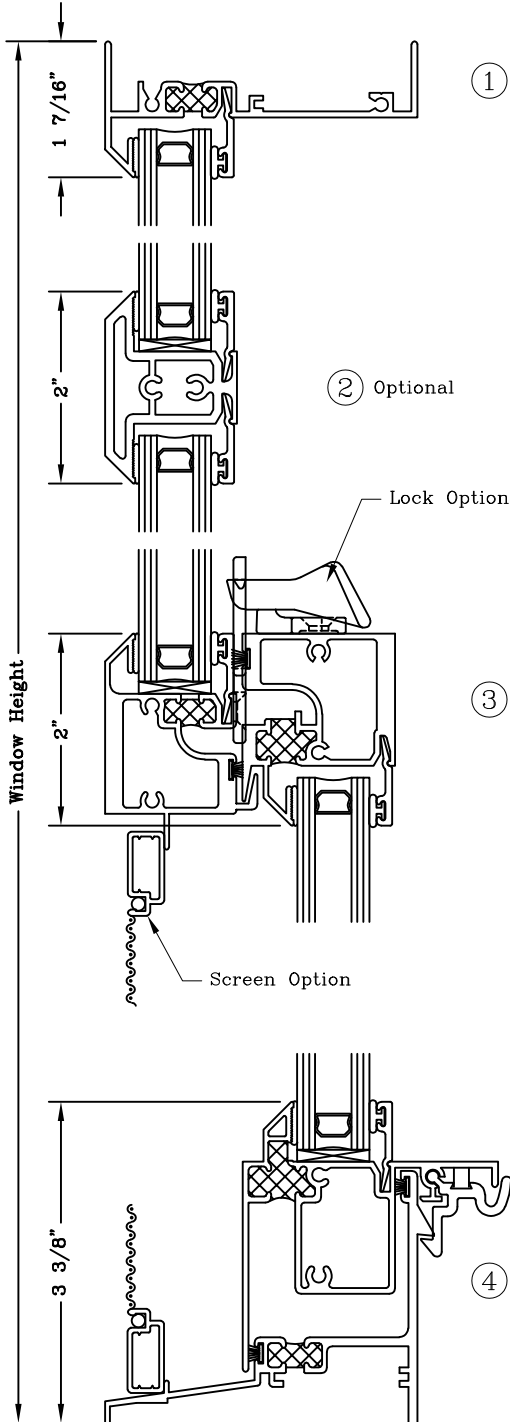

ELEVATION

Optional True Muntin Available
For Fixed Lite And Operable Sash

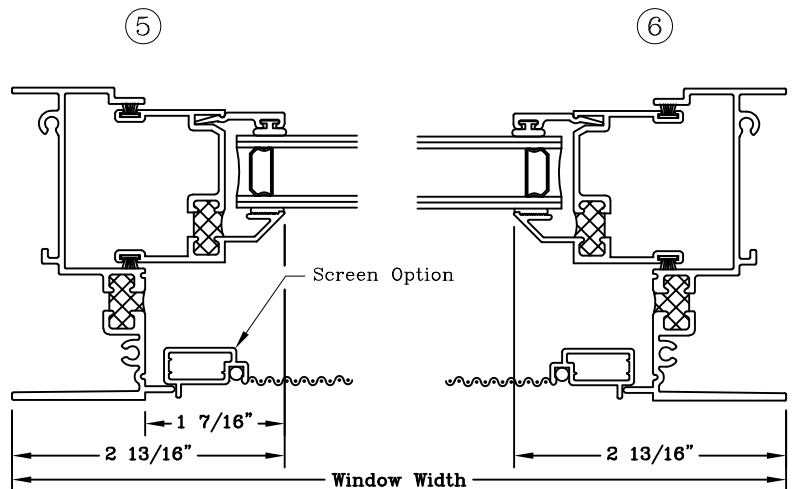

Graham Architectural Products reserves the right to change, add, cancel, remove or otherwise modify the details illustrated without prior notice.

1551 Mt. Rose Avenue, York, Pennsylvania 17403-2909 717.849.8100 Toll Free: 800/755-6274

Web Site: www.grahamwindows.com

0223 - 20.09

Single Hung Side Load 3 1/4" Historic Beveled Frame Sills Frame Options



Series: 2000H Manufacturing Code: 2010

Drawing 1/2 Scale - For Custom Size Drawing Contact Graham

Note: Sealant Not Shown On Details. Refer To General Installation Instructions.

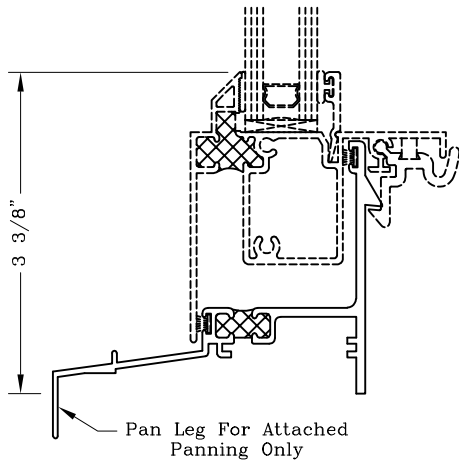

200321
Pan Leg Sill With Spring Latch Barb

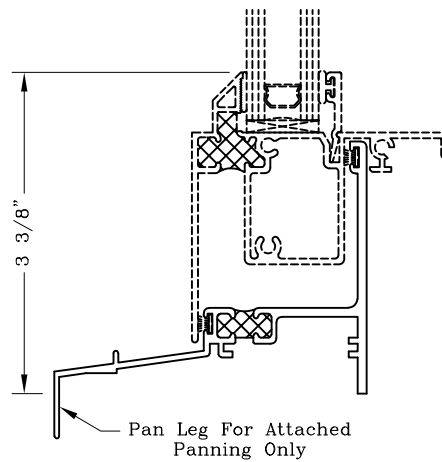

200323
Pan Leg Sill Without Spring Latch Barb

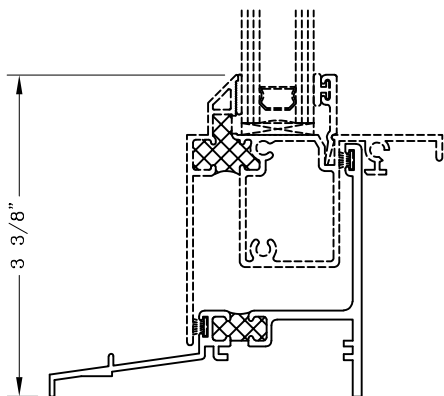

200322
Sill Without Spring Latch Barb

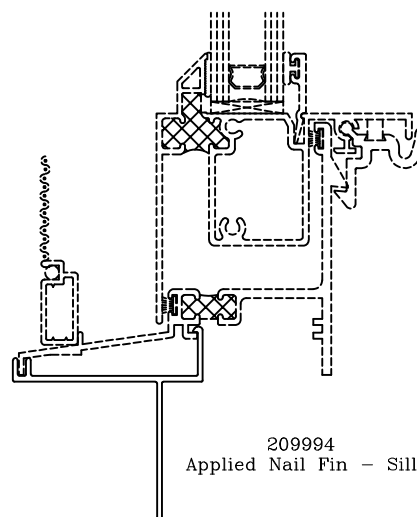

209994
Applied Nail Fin - Sill

Graham Architectural Products reserves the right to change, add, cancel, remove or otherwise modify the details illustrated without prior notice.

1551 Mt. Rose Avenue, York, Pennsylvania 17403-2909 717.849.8100 Toll Free: 800/755-6274

0223 - 20.10

Web Site: www.grahamwindows.com

Single Hung Side Load 3 1/4" Historic Beveled Frame Heads Frame Options



Series: 2000H Manufacturing Code: 2011

Drawing 1/2 Scale – For Custom Size Drawing Contact Graham

Note: Sealant Not Shown On Details. Refer To General Installation Instructions.

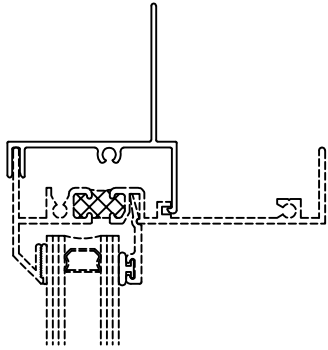

209995
Applied Nail Fin w/ Screw Port

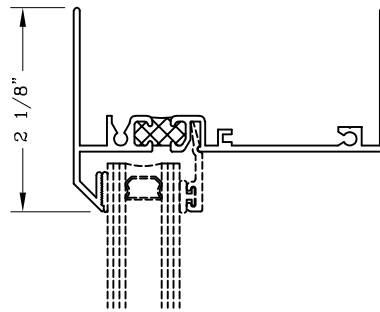

200315
2 1/8" Sightline Head

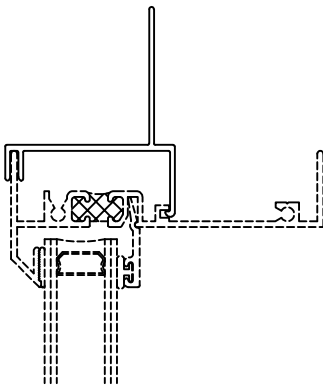

209993
Applied Nail Fin – Head

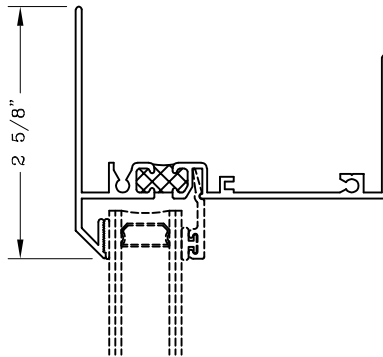

200319
Fixed Head with 1/2" Flange

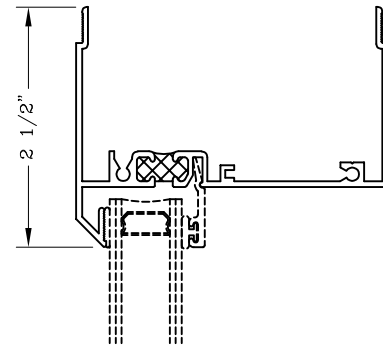

200316
Fixed Head for Stacking

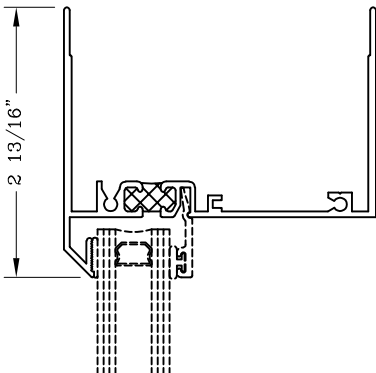

200317
2 13/16" Sightline Head

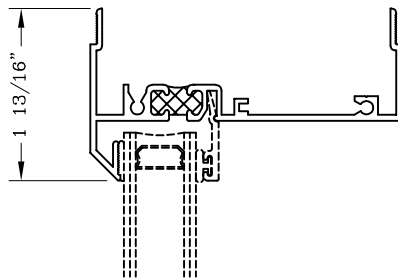

200311
Fixed Head for Stacking

Graham Architectural Products reserves the right to change, add, cancel, remove or otherwise modify the details illustrated without prior notice.

1551 Mt. Rose Avenue, York, Pennsylvania 17403-2909 717.849.8100 Toll Free: 800/755-6274

Web Site: www.grahamwindows.com

0223 – 20.11

Single Hung Side Load 3 1/4" Historic Beveled Jambs and Sash Frame Options



Series: 2000H Manufacturing Code: 2012

Drawing 1/2 Scale - For Custom Size Drawing Contact Graham

Note: Sealant Not Shown On Details. Refer To General Installation Instructions.

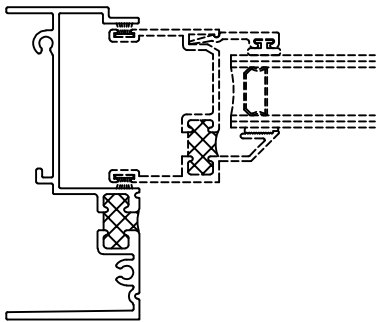

200334
Non Screen Leg Jamb

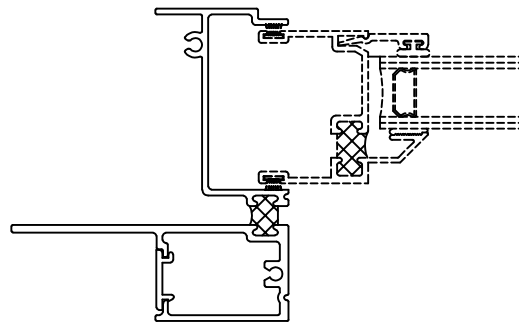

203037
Non Screen Leg Nail Fin Jamb

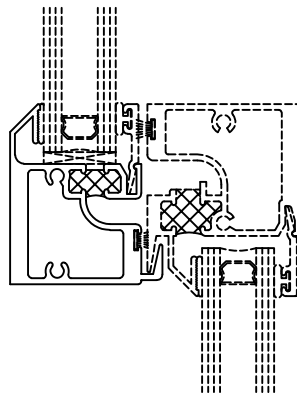

200351
Non Screen Leg Meeting Rail

Single Hung Over Fixed - 3 1/4"



Series: 2000

Manufacturing Code: 2013

Drawing 1/2 Scale - For Custom Size Drawing Contact Graham

Note: Sealant Not Shown On Details. Refer To General Installation Instructions.

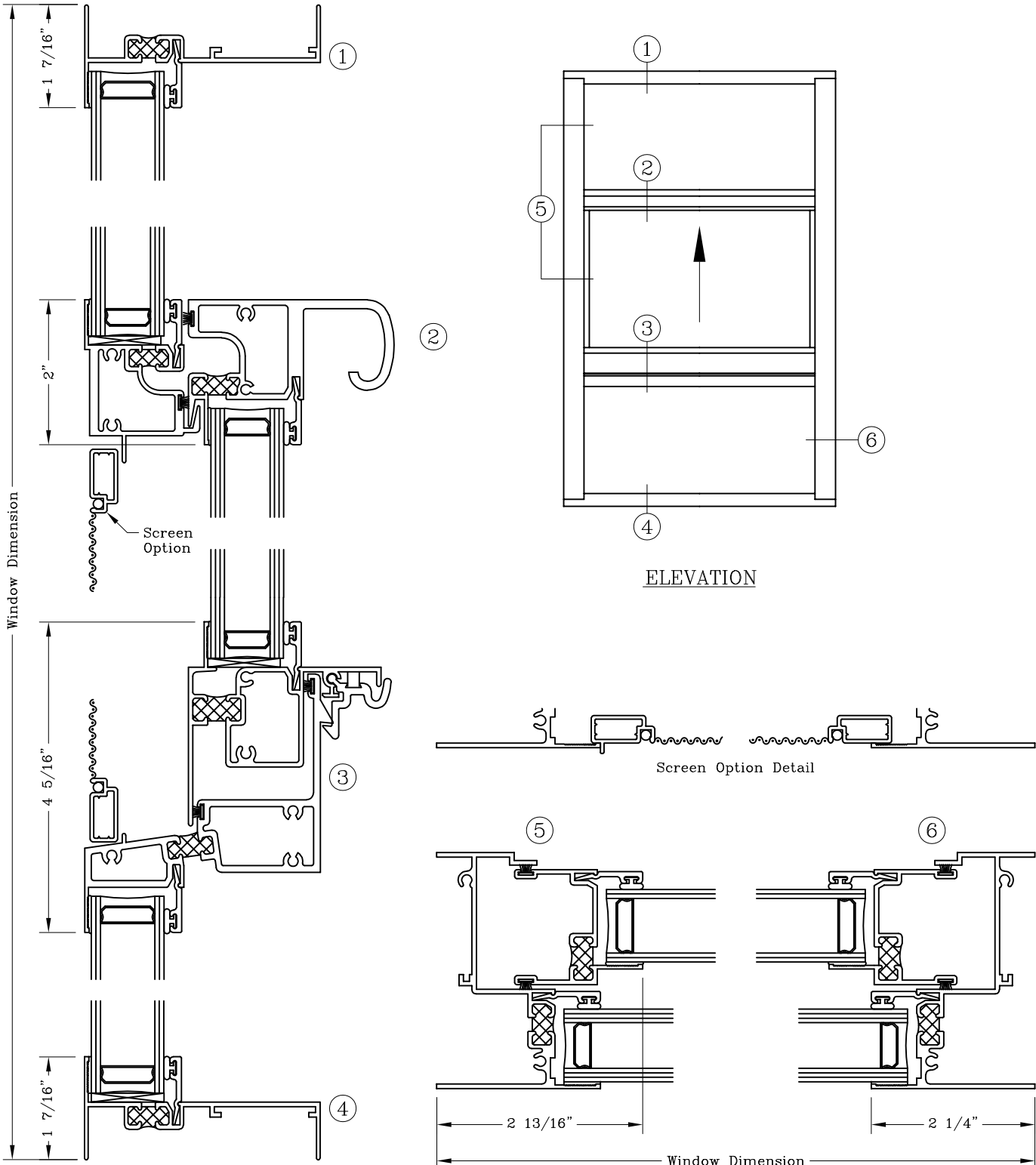

Graham Architectural Products reserves the right to change, add, cancel, remove or otherwise modify the details illustrated without prior notice.

Single Hung Over Fixed - 3 1/4"



Series: 2000H

Manufacturing Code: 2014

Drawing 1/2 Scale - For Custom Size Drawing Contact Graham

Note: Sealant Not Shown On Details. Refer To General Installation Instructions.

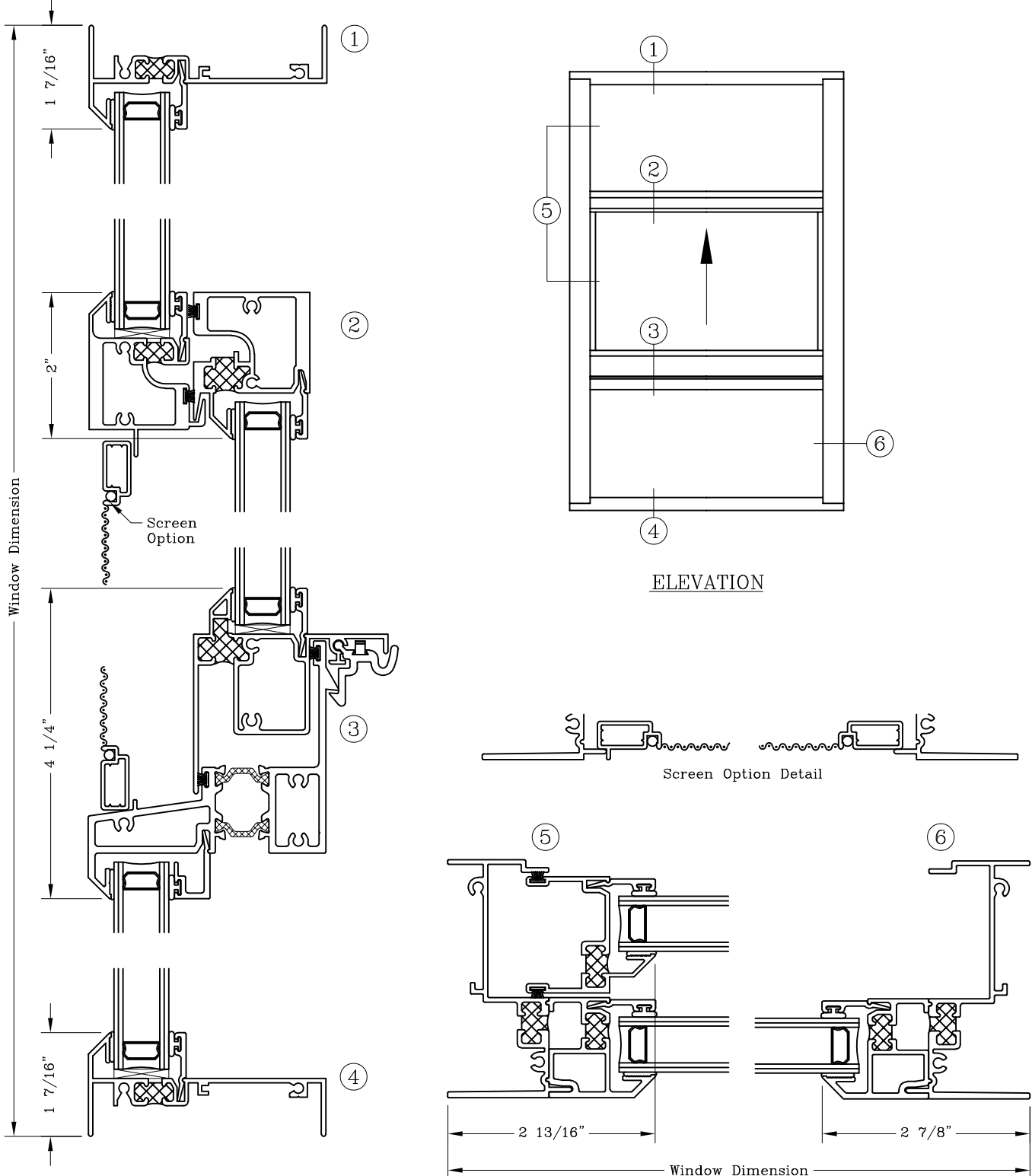

Graham Architectural Products reserves the right to change, add, cancel, remove or otherwise modify the details illustrated without prior notice.

1551 Mt. Rose Avenue, York, Pennsylvania 17403-2909 717.849.8100 Toll Free: 800/755-6274

0223 - 20.14

Web Site: www.grahamwindows.com

Frame Options – 3 1/4” Flat Frame Sills



Series: 2000

Manufacturing Code: 2015

Drawing 1/2 Scale – For Custom Size Drawing Contact Graham

Note: Sealant Not Shown On Details. Refer To General Installation Instructions.

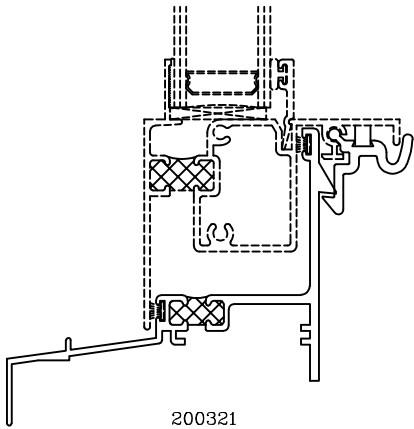

200321
Frame Sill w/ Pan Leg

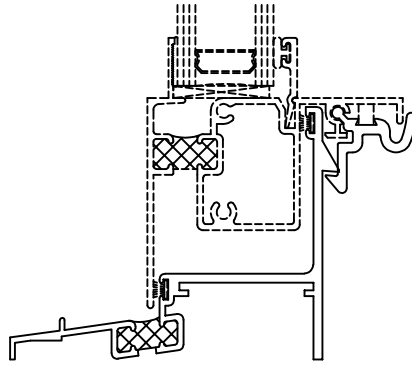

200026
Flat Equal Leg Sill

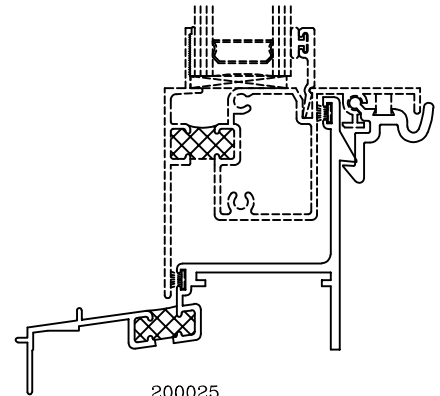

200025
Flat Pan Leg Sill

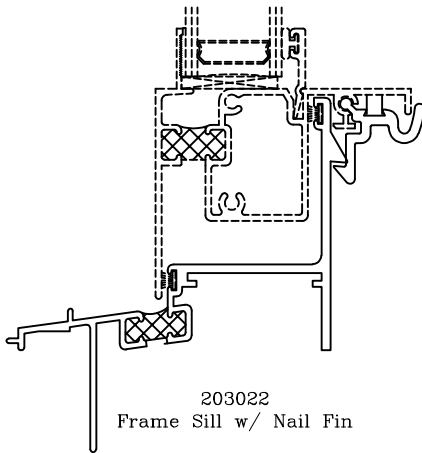

203022
Frame Sill w/ Nail Fin

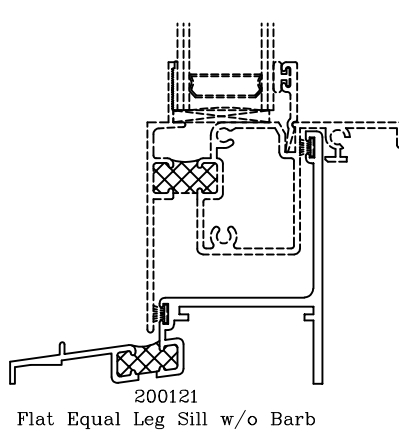

200121
Flat Equal Leg Sill w/o Barb

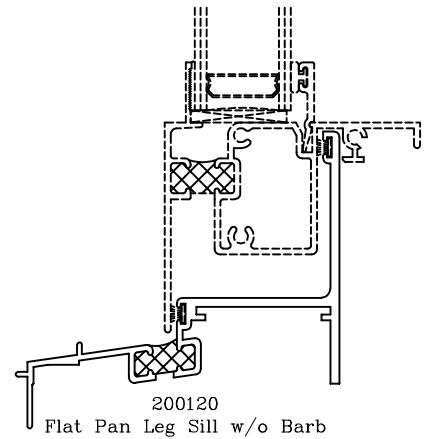

200120
Flat Pan Leg Sill w/o Barb

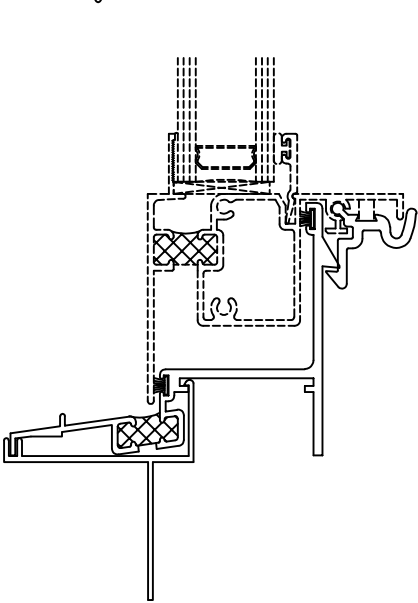

209997
Applied Nail Fin - Sill

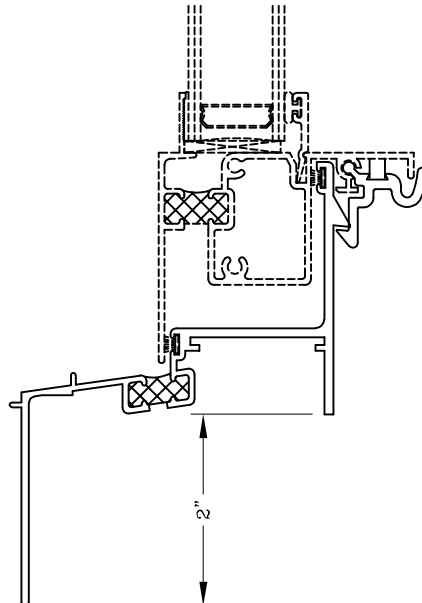

200028
Flat 2" Flange Frame Sill

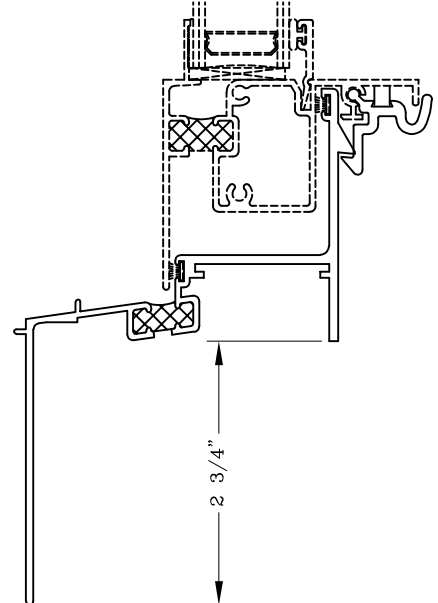

200027
Frame Sill w/ 2 3/4" Flange

Graham Architectural Products reserves the right to change, add, cancel, remove or otherwise modify the details illustrated without prior notice.

1551 Mt. Rose Avenue, York, Pennsylvania 17403-2909 717.849.8100 Toll Free: 800/755-6274

0223 – 20.15

Web Site: www.grahamwindows.com

Frame Options – 3 1/4” Flat Frame Heads



Series: 2000

Manufacturing Code: 2016

Drawing 1/2 Scale – For Custom Size Drawing Contact Graham

Note: Sealant Not Shown On Details. Refer To General Installation Instructions.

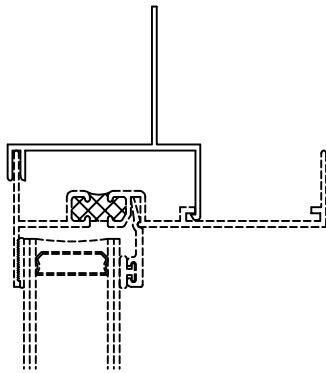

209996
Applied Nail Fin – Head

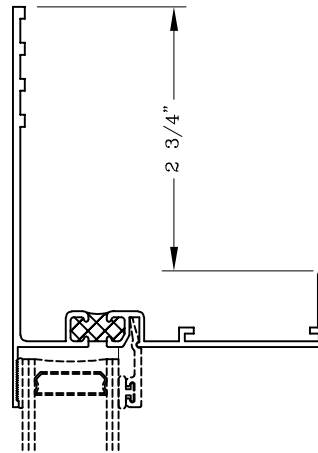

200012
Frame Head w/ 2 3/4” Flange

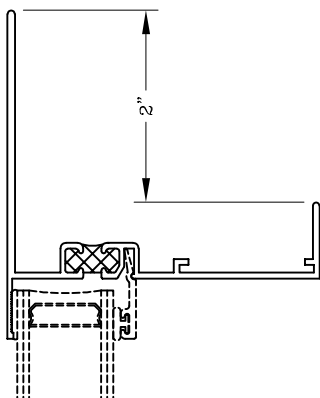

200013
Frame Head w 2” Flange

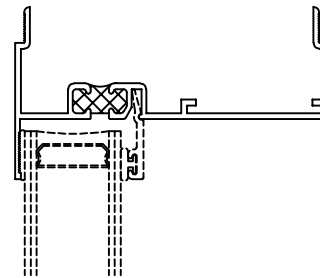

200011
Frame Head Self-Mull

Frame Options – 3 1/4” Flat Frame Jambs



Series: 2000

Manufacturing Code: 2017

Drawing 1/2 Scale – For Custom Size Drawing Contact Graham

Note: Sealant Not Shown On Details. Refer To General Installation Instructions.

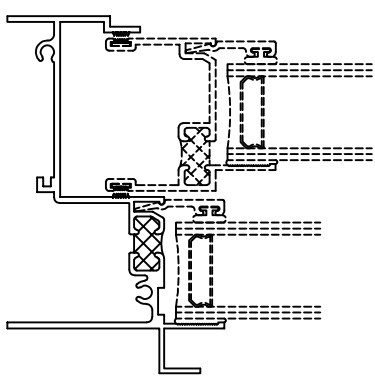

203030
Frame Jamb Equal Leg w/ Screen Track

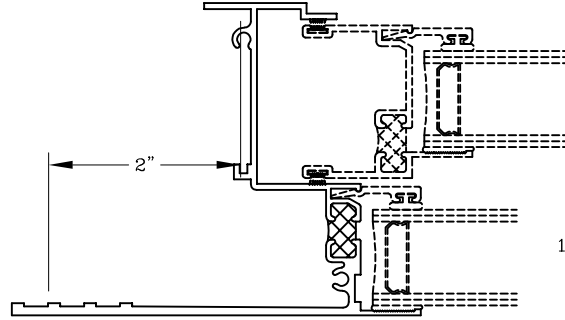

200035
Frame Jamb w/ 2” Flange

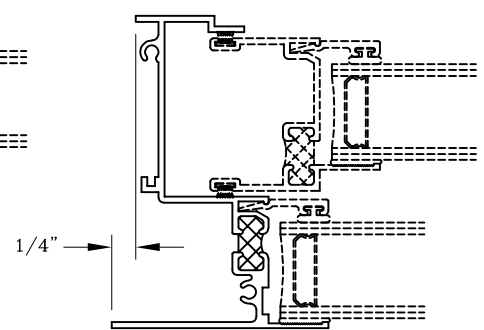

200039
Frame Jamb w/ Offset Leg

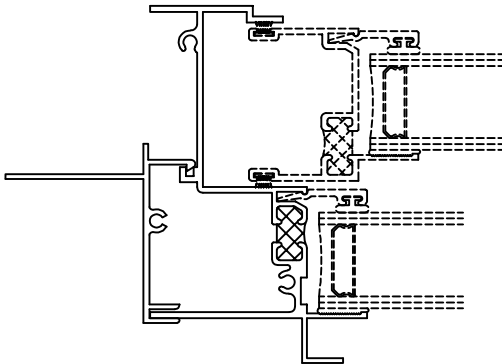

209998
Applied Nail Fin - Jamb

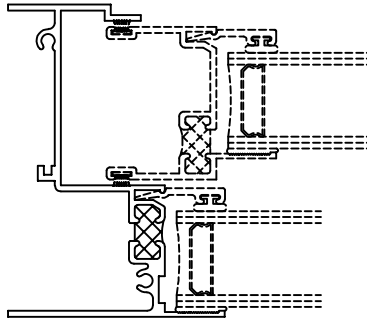

200030
Frame Jamb w/ Equal Leg

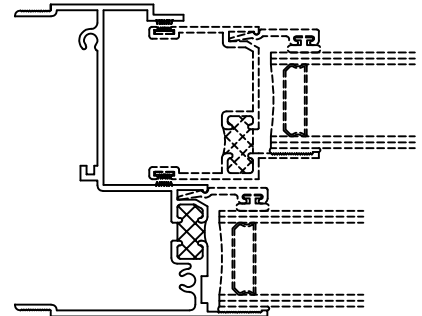

200031
Frame Jamb Self Mull

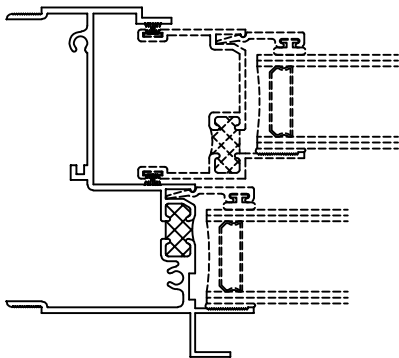

203031
Flat Self-Mull Jamb

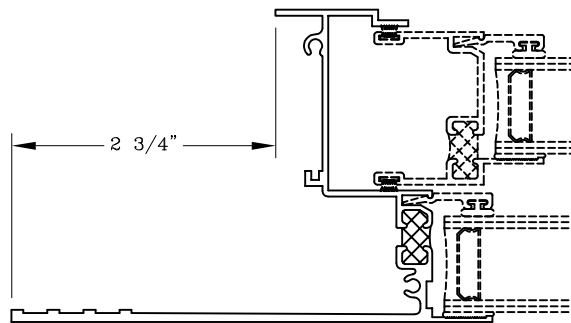

200032
Flat 2 3/4” Flange Frame Jamb

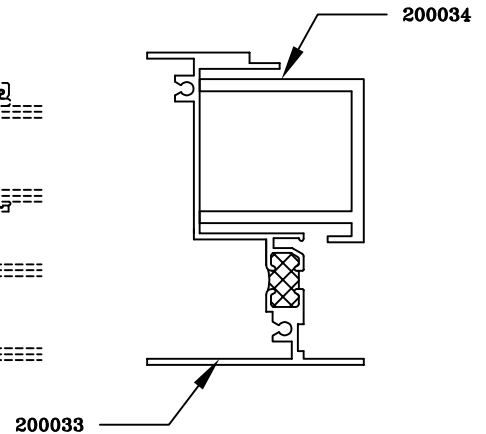

200033
Channel and Jamb Frame For Curving

Graham Architectural Products reserves the right to change, add, cancel, remove or otherwise modify the details illustrated without prior notice.

1551 Mt. Rose Avenue, York, Pennsylvania 17403-2909 717.849.8100 Toll Free: 800/755-6274

0223 – 20.17

Web Site: www.grahamwindows.com