

Double Hung Side Load - 4 1/2"



Series: GT2500

Manufacturing Code: GT2501

Drawing 1/2 Scale - For Custom Size Drawing Contact Graham

Note: Sealant Not Shown On Details. Refer To General Installation Instructions.

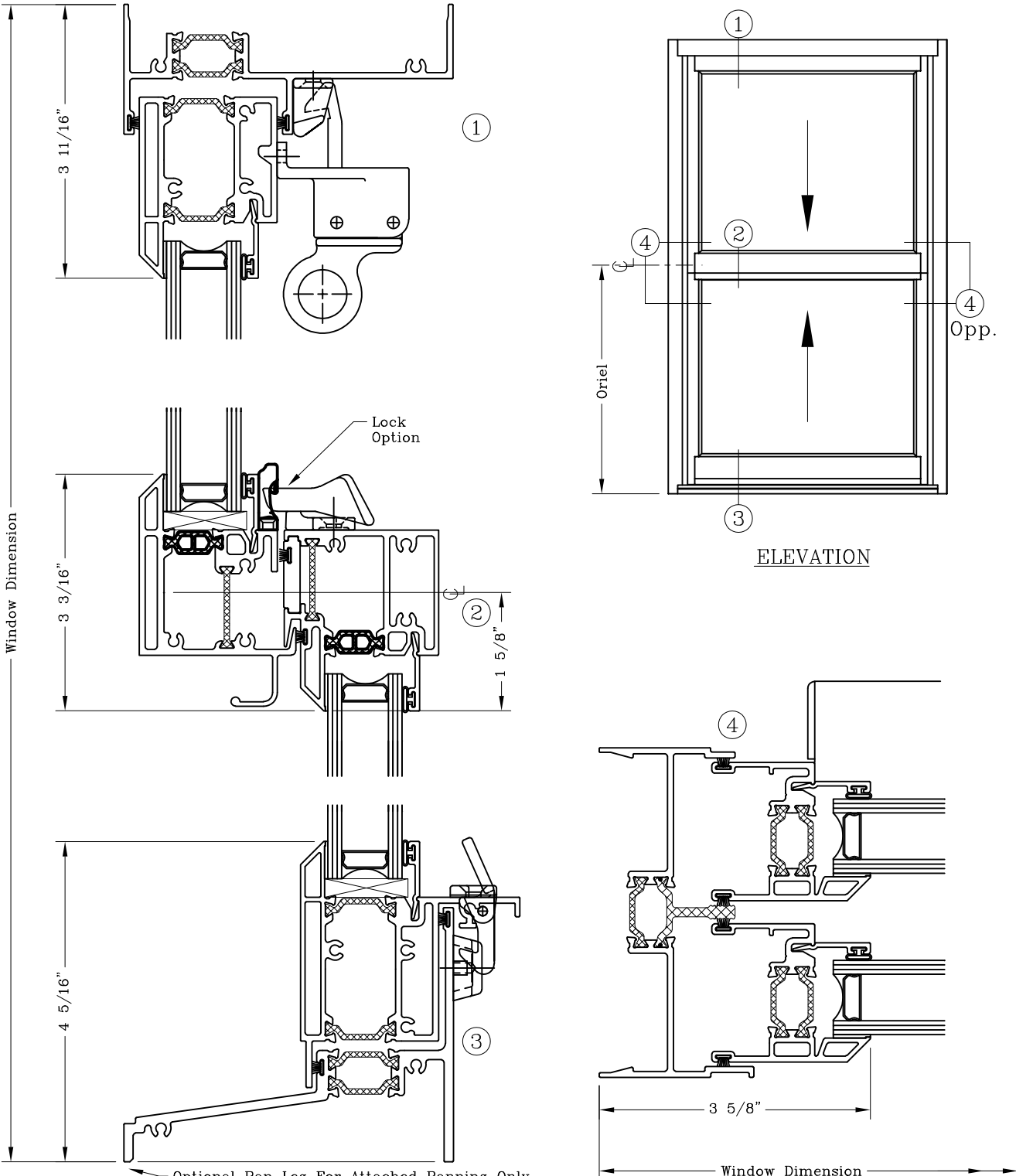

Double Hung Side Load - 4 1/2" Astragal



Series: GT2500 Manufacturing Code: GT2502

Drawing 3/8 Scale - For Custom Size Drawing Contact Graham

Note: Sealant Not Shown On Details. Refer To General Installation Instructions.

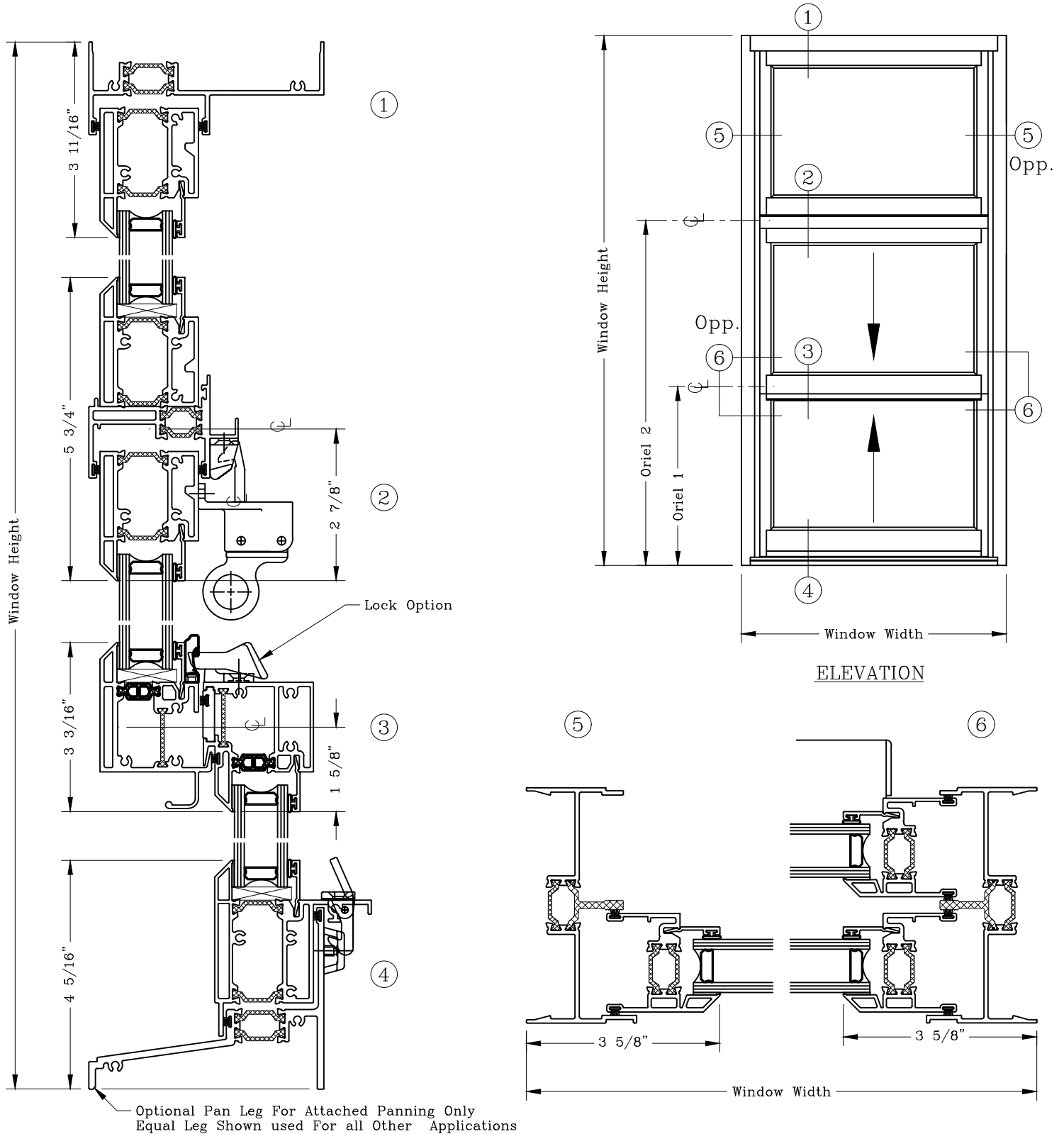

Graham Architectural Products reserves the right to change, add, cancel, remove or otherwise modify the details illustrated without prior notice.

1551 Mt. Rose Avenue, York, Pennsylvania 17403-2909 717.849.8100 Toll Free: 800/755-6274

0124 - GT25.02

Web Site: www.grahamwindows.com

Overhead Pulley Counter Balanced Double Hung - 4 1/2"



Series: GT2500

Manufacturing Code: GT2505

Drawing 1/2 Scale - For Custom Size Drawing Contact Graham

Note: Sealant Not Shown On Details. Refer To General Installation Instructions.

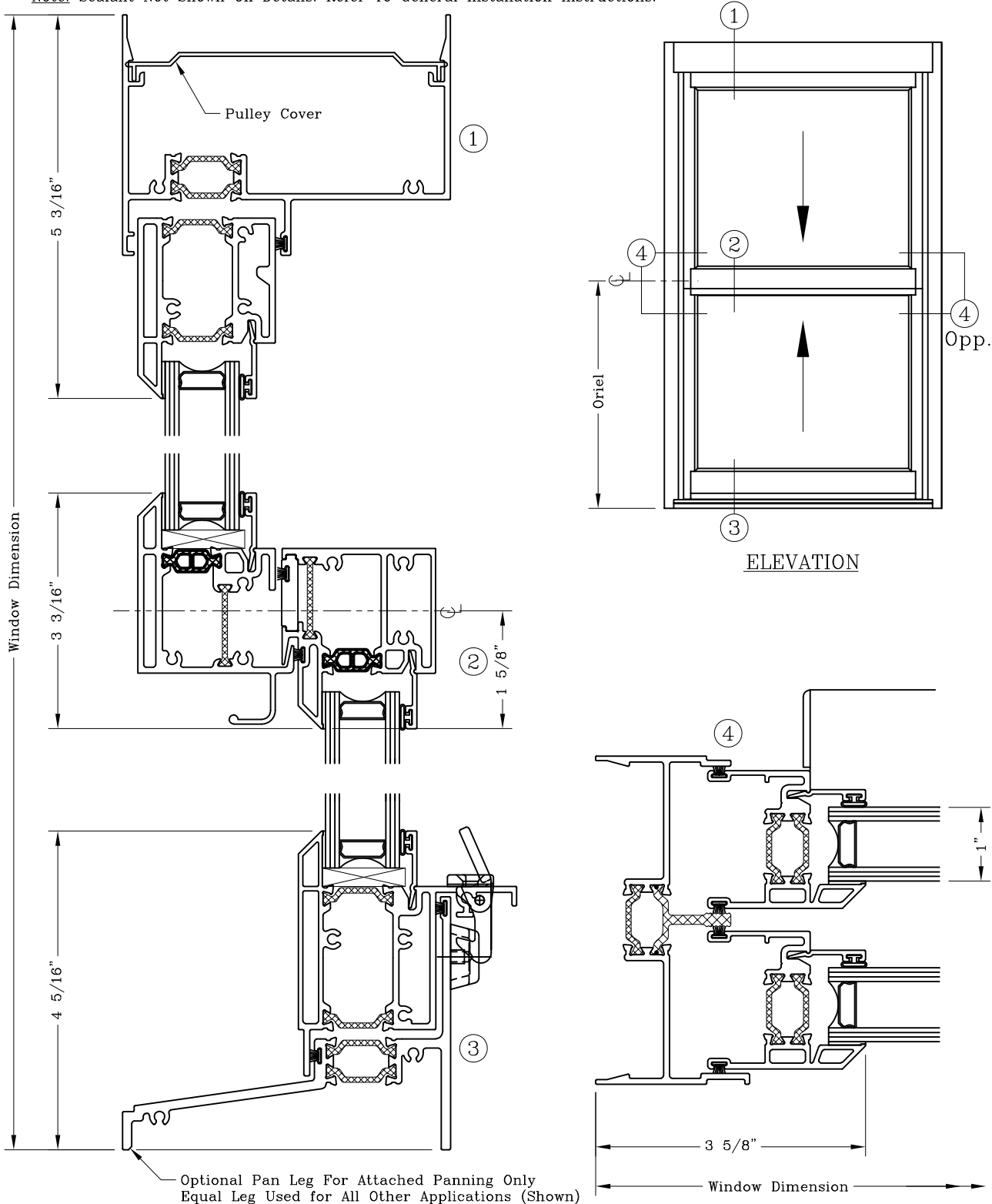

Optional Pan Leg For Attached Panning Only
Equal Leg Used for All Other Applications (Shown)

Graham Architectural Products reserves the right to change, add, cancel, remove or otherwise modify the details illustrated without prior notice.

1551 Mt. Rose Avenue, York, Pennsylvania 17403-2909 717.849.8100 Toll Free: 800/755-6274

0223 - GT25.05

Web Site: www.grahamwindows.com

By-pass Screens - 4 1/2"

GT 2500 Double Hung



Series: Accessories Manufacturing Code: SC08

Drawing 1/2 Scale - For Custom Size Drawing Contact Graham

Note: Sealant Not Shown On Details. Refer To General Installation Instructions.

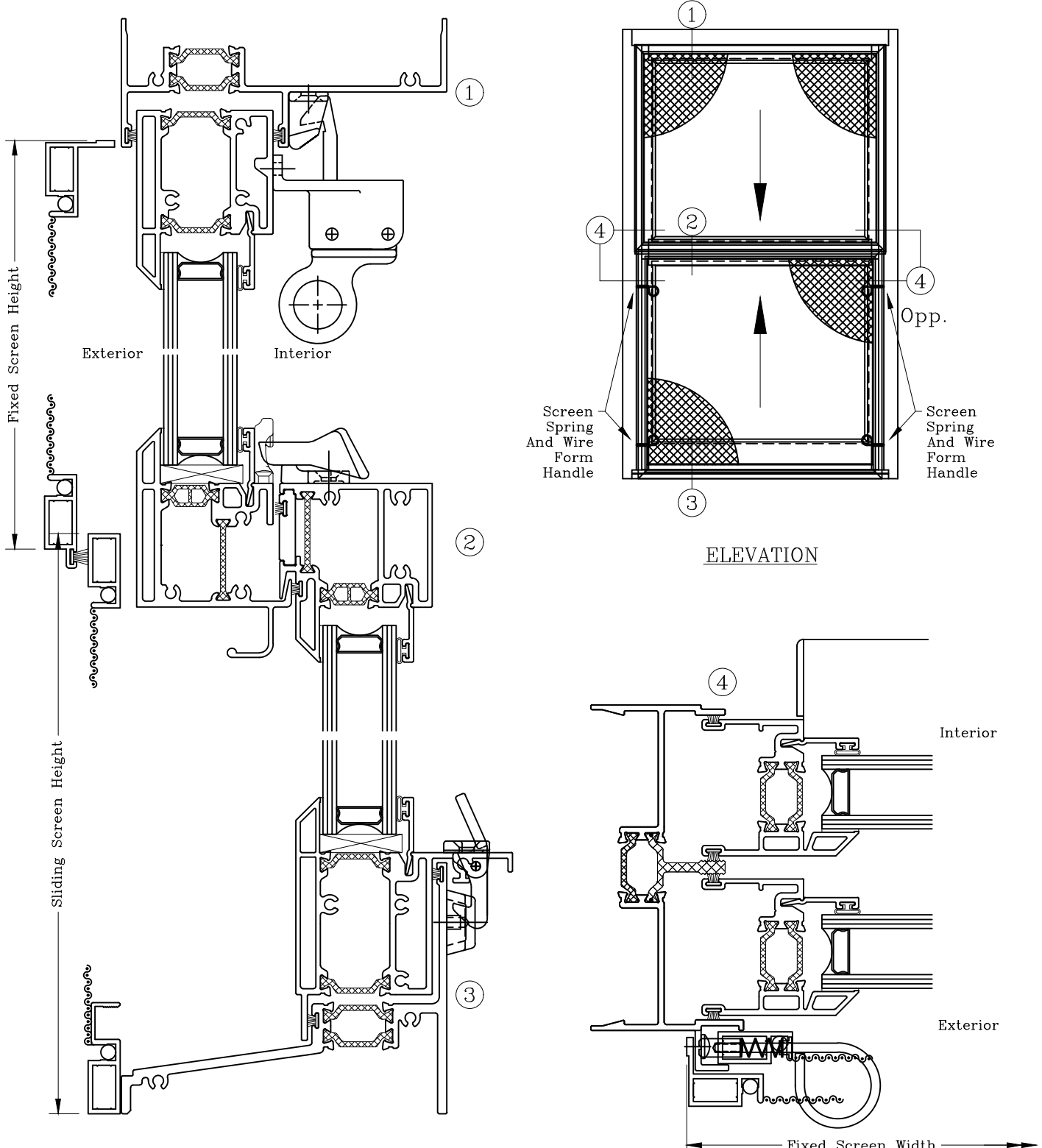

Graham Architectural Products reserves the right to change, add, cancel, remove or otherwise modify the details illustrated without prior notice.

1551 Mt. Rose Avenue, York, Pennsylvania 17403-2909 717.849.8100 Toll Free: 800/755-6274

0823 - SC.08

Web Site: www.grahamwindows.com