

GRAHAM ARCHITECTURAL PRODUCTS, INC.

GT6700 FIXED WINDOW (LARGE MISSILE IMPACT RATED - NON-HVHZ)

FRANK BENNARDO, P.E.
PE# 0046549 CA, 9885



04/19/2021

FL# 38522.1



CORPORATE OFFICE:
160 SW 12th AVE, SUITE 106
DEERFIELD BEACH, FL 33442
(954) 354-0660 | (866) 396-9999
TEAM@ENGINEERINGEXPRESS.COM
ENGINEERINGEXPRESS.COM

GRAHAM ARCHITECTURAL PRODUCTS
1551 MT. ROSE AVENUE | YORK, PA 17403
PH: (717) 849-8100

SERIES GT6700 FIXED
FLORIDA STATEWIDE APPROVAL
FLORIDA BUILDING CODE 7TH EDITION (2020)

REMARKS	DRWN	CHKD	DATE
FBC 2020 UPDATE	TAE	AJP	04/01/21

COPYRIGHT ENGINEERING EXPRESS®

21-38803

SCALE: NTS UNLESS NOTED

16

01

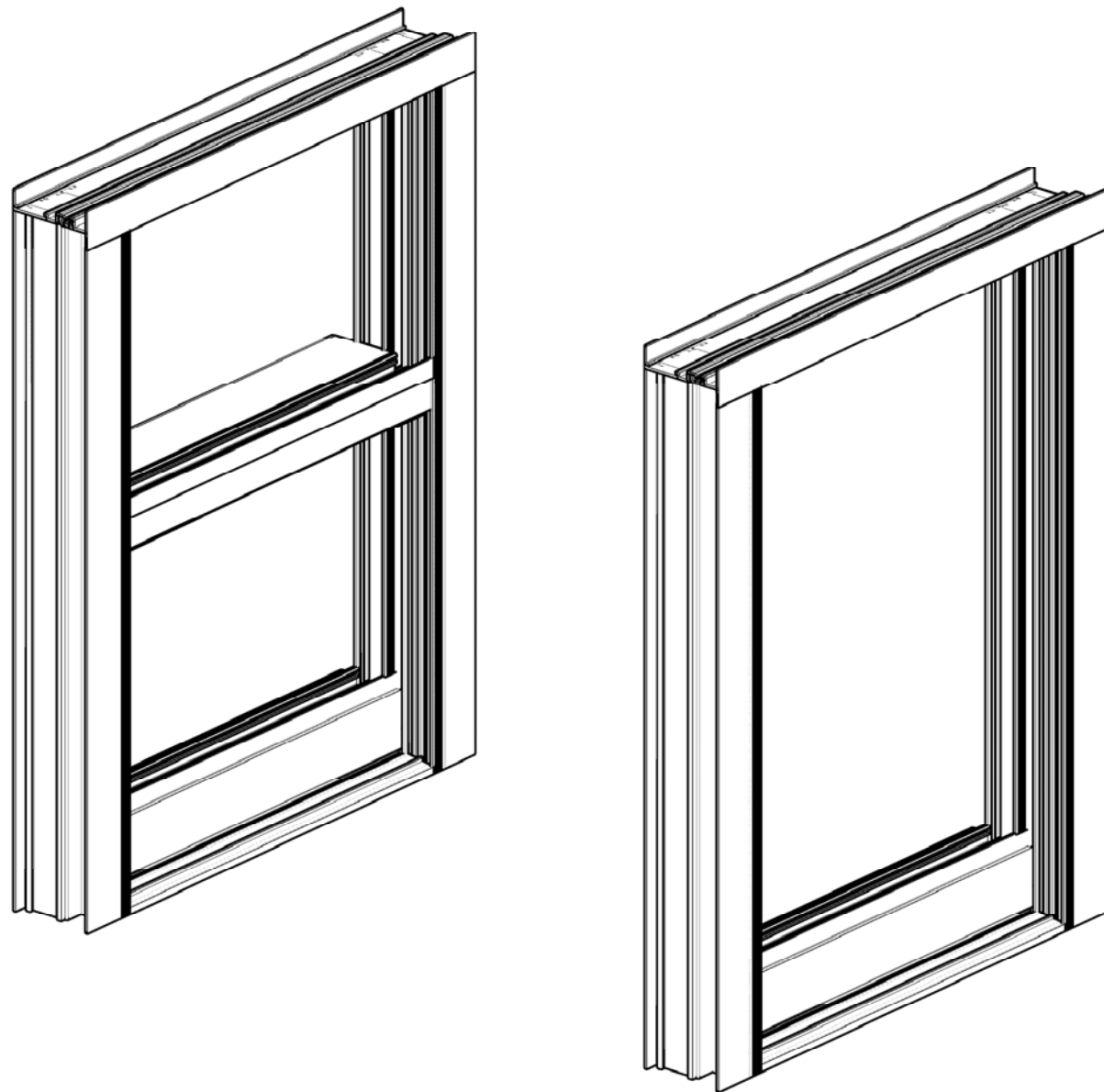

GENERAL NOTES:

- THIS SYSTEM AND GLASS TYPES DESCRIBED HEREIN COMPLY AND HAVE BEEN DESIGNED AND TESTED IN ACCORDANCE WITH THE FLORIDA BUILDING CODE SEVENTH EDITION (2020) PER
 - ASTM E1996-17 / E1886-12
 - AAMA 506-16
- SITE-SPECIFIC REQUIRED DESIGN PRESSURES SHALL BE CALCULATED BY A LICENSED PROFESSIONAL ENGINEER FOR USE WITH THIS DOCUMENT PER CURRENT ADOPTED EDITION OF ASCE 7 AND WITH LOCAL CODE REQUIREMENTS.
- THIS SYSTEM IS IMPACT RATED FOR WIND ZONE IV, NON-HVHZ.
- DESIGN PRESSURES NOTED HEREIN ARE BASED ON MAXIMUM TESTED PRESSURES DIVIDED BY A 1.5 SAFETY FACTOR.
- NO 33-1/3% INCREASE IN ALLOWABLE STRESS HAS BEEN USED IN THE DESIGN OF THIS SYSTEM. WIND LOAD DURATION FACTOR $C_d=1.6$ HAS BEEN USED FOR WOOD ANCHOR DESIGN.
- THE ARCHITECT/ENGINEER OF RECORD FOR THE PROJECT SUPERSTRUCTURE WITH WHICH THIS DESIGN IS USED SHALL BE RESPONSIBLE FOR THE INTEGRITY OF ALL SUPPORTING SURFACES TO THIS DESIGN WHICH SHALL BE COORDINATED BY THE PERMITTING CONTRACTOR. WOOD BUCKS (BY OTHERS) SHALL BE ANCHORED PROPERLY TO TRANSFER LOADS TO THE EXISTING STRUCTURE.
- THE SYSTEM DETAILED HEREIN IS GENERIC AND DOES NOT PROVIDE INFORMATION FOR A SPECIFIC SITE. FOR SITE CONDITIONS DIFFERENT FROM THE CONDITIONS DETAILED HEREIN, A LICENSED ENGINEER OR REGISTERED ARCHITECT SHALL PREPARE SITE SPECIFIC DOCUMENTS FOR USE IN CONJUNCTION WITH THIS DOCUMENT.
- THE CONTRACTOR IS RESPONSIBLE TO INSULATE ALL MEMBERS FROM DISSIMILAR MATERIALS TO PREVENT ELECTROLYSIS.
- FASTENERS SHALL BE CADMIUM-PLATED OR OTHERWISE CORROSION-RESISTANT MATERIAL AND SHALL COMPLY WITH "SPECIFICATIONS FOR ALUMINUM STRUCTURES" SECTION 1.3.7.2 BY THE ALUMINUM ASSOCIATION, INC., & ANY APPLICABLE FEDERAL, STATE, AND/OR LOCAL CODES
- ENGINEER SEAL AFFIXED HERE TO VALIDATES STRUCTURAL DESIGN AS SHOWN ONLY. USE OF THIS SPECIFICATION BY CONTRACTOR, et. al. INDEMNIFIES & SAVES HARMLESS THIS ENGINEER FOR ALL COST & DAMAGES INCLUDING LEGAL FEES & APPELLATE FEES RESULTING FROM MATERIAL FABRICATION, SYSTEM ERECTION, & CONSTRUCTION PRACTICES BEYOND THAT WHICH IS CALLED FOR BY LOCAL, STATE, & FEDERAL CODES & FROM DEVIATIONS OF THIS PLAN.
- EXCEPT AS EXPRESSLY PROVIDED HEREIN, NO ADDITIONAL CERTIFICATIONS OR AFFIRMATIONS ARE INTENDED.
- PRESSURE VALUES ON THIS APPROVAL ARE (ASD) ALLOWABLE DESIGN PRESSURES.
- ALTERATIONS, ADDITIONS, OR OTHER MARKINGS TO THIS DOCUMENT ARE NOT PERMITTED AND INVALIDATE THIS CERTIFICATION.
- SAFEGUARDS MUST BE OBSERVED (NOT IN THIS CERTIFICATION)
- PRODUCT SHALL BE PERMANENTLY LABELED WITH A MINIMUM OF ONE LABEL PER SYSTEM CONTAINING THE FOLLOWING:
GRAHAM ARCHITECTURAL PRODUCTS, INC
1551 MT. ROSE AVE.
YORK, PA 17403

SHEET INDEX

# SHEET	DESCRIPTION
01	COVER SHEET
02	ELEVATIONS
03-04	GLAZING DETAILS & GLASS LOADING TABLES
05-06	FRAME LOADING TABLES
07-10	ANCHOR SCHEDULE & ANCHOR LOADING TABLES
11-14	DETAILS
15-16	EXTRUSIONS / PART LIST
16	TOTAL

VISIT ECALC.IO/38803

FOR HELPFUL RESOURCES, SITE SPECIFIC JOB ORDERING & MORE INFORMATION ABOUT THIS PRODUCT & RELATED SERVICES



ELEVATIONS

FRANK BENNARDO, P.E.
PE# 0046549 CA, 9885

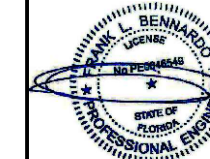

04/19/2021

FL# 38522.1

ENGINEERING EXPRESS
CORPORATE OFFICE:
160 SW 12th AVE, SUITE 106
DEERFIELD BEACH, FL 33442
(954) 354-0660 | (866) 396-9999
TEAM@ENGINEERINGEXPRESS.COM
ENGINEERINGEXPRESS.COM

GRAHAM ARCHITECTURAL PRODUCTS
1551 MT. ROSE AVENUE | YORK, PA 17403
PH: (717) 849-8100
SERIES GT6700 FIXED
FLORIDA STATEWIDE APPROVAL
FLORIDA BUILDING CODE 7TH EDITION (2020)

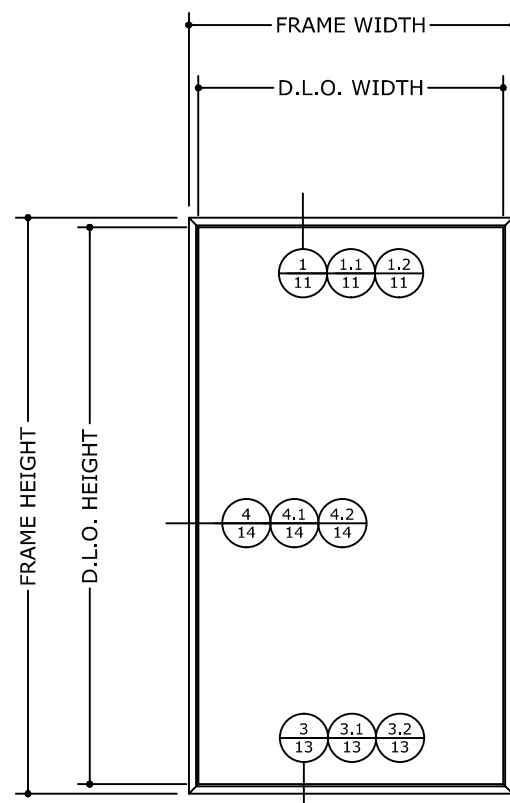

TYPICAL FIXED ELEVATION

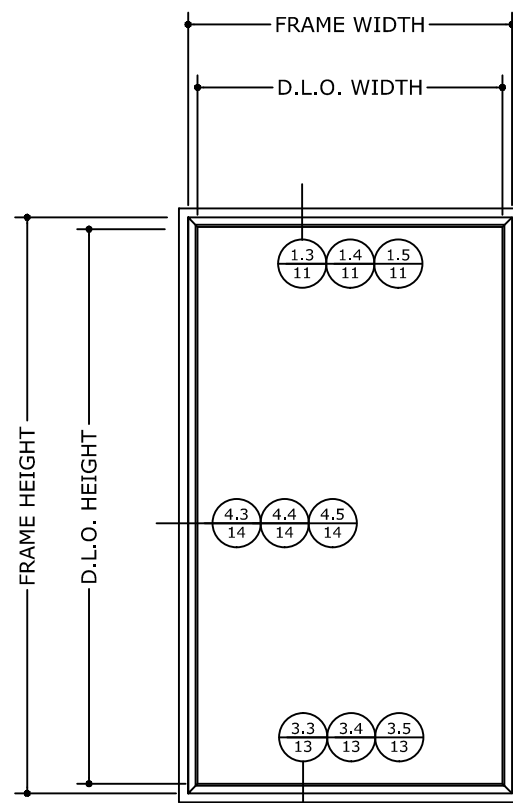

TYPICAL FIXED ELEVATION WITH RECEPTOR

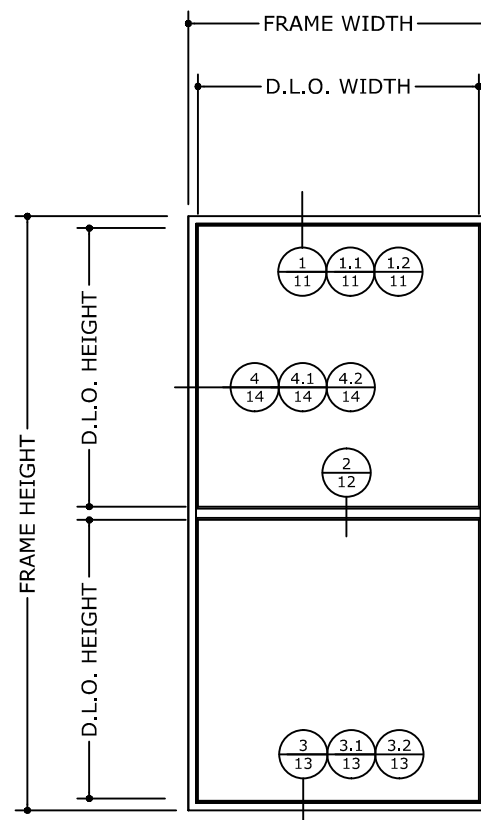

TYPICAL FIXED ELEVATION WITH INTERMEDIATE HORIZONTAL

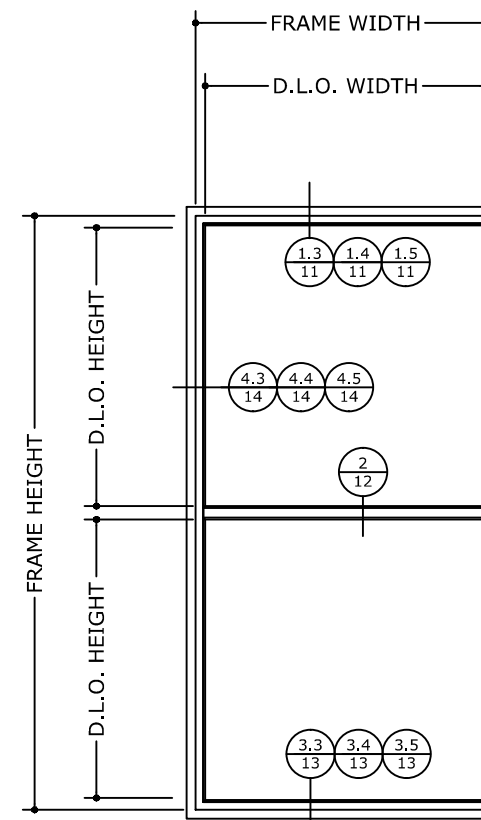

TYPICAL FIXED ELEVATION WITH INTERMEDIATE HORIZONTAL AND RECEPTOR

INSTRUCTIONS TO DETERMINE DESIGN PRESSURE RATING

- STEP ①: USE THE GLASS LOADING TABLES TO DETERMINE THE ALLOWABLE PRESSURE OF THE GLASS.
- STEP ②: USE THE FRAME LOADING TABLE TO DETERMINE THE ALLOWABLE PRESSURES.
- STEP ③: THE MINIMUM VALUE BETWEEN STEP ① AND STEP ② WILL DETERMINE THE DESIGN LOAD PRESSURE FOR THE WINDOW SYSTEM.

MAX D.L.O. AREA WITHOUT HORIZONTAL = 32.6 SQ. FT
MAX D.L.O. AREA WITH HORIZONTAL = 12.58 SQ. FT

MAXIMUM ALLOWABLE DESIGN PRESSURES:
+70 PSF, -90 PSF

REMARKS	DRWN	CHKD	DATE
FBC 2020 UPDATE	TAE	AJP	04/01/21

COPYRIGHT ENGINEERING EXPRESS®

21-38803

SCALE: NTS UNLESS NOTED

02 16

GLASS TYPES

NOTE: GLASS SIZE = DLO + 1"

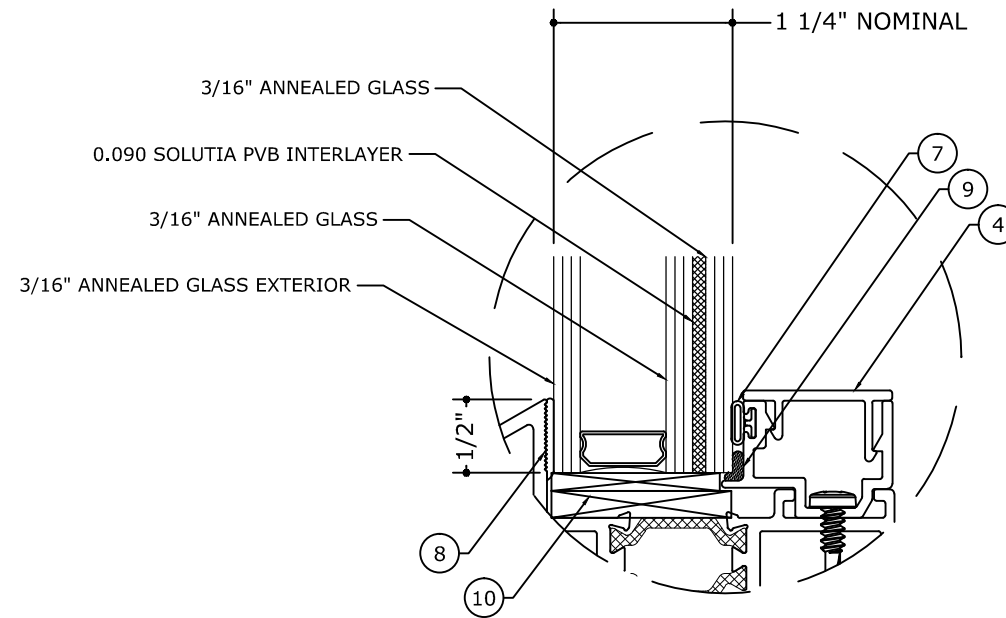

GLASS TYPE **G1**

GLAZING DETAIL

N.T.S.

GLASS RATING:
LARGE MISSILE IMPACT
MISSILE LEVEL D

NOTE: GLAZING TYPE COMPLIES WITH ASTM E1300 REQUIREMENTS.

FRANK BENNARDO, P.E.
PE# 0046549 CA. 9885

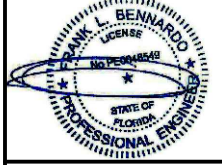

04/19/2021

FL# 38522.1

ENGINEERING EXPRESS
CORPORATE OFFICE:
160 SW 12th AVE, SUITE 106
DEERFIELD BEACH, FL 33442
(954) 354-0660 | (866) 396-9999
TEAM@ENGINEERINGEXPRESS.COM
ENGINEERINGEXPRESS.COM

GRAHAM ARCHITECTURAL PRODUCTS
1551 MT. ROSE AVENUE | YORK, PA 17403
PH: (717) 849-8100

SERIES GT6700 FIXED
FLORIDA STATEWIDE APPROVAL
FLORIDA BUILDING CODE 7TH EDITION (2020)

REMARKS	DRWN	CHKD	DATE
FBC 2020 UPDATE	TAE	AJP	04/01/21

COPYRIGHT ENGINEERING EXPRESS®

21-38803

SCALE: NTS UNLESS NOTED

03

16

GLASS LOADING TABLES

GLASS TYPES		G1	
		ALLOWABLE PRESSURE	
D.L.O. HEIGHT (in)	D.L.O. WIDTH (in)	(+) P.S.F.	(-) P.S.F.
24	24	70	90
	31	70	90
	38 3/4	70	90
	42	70	90
	48	70	90
	50 3/4	70	90
	56	70	90
	64	70	90
	70	70	90
31	24	70	90
	31	70	90
	38 3/4	70	90
	42	70	90
	48	70	90
	50 3/4	70	90
	56	70	90
	64	70	90
	70	70	90
36	24	70	90
	31	70	90
	38 3/4	70	70
	42	70	70
	48	70	70
	50 3/4	70	70
	56	70	70
	64	70	90
	70	70	90
42	24	70	90
	31	70	90
	38 3/4	70	90
	42	70	90
	48	70	90
	50 3/4	70	90
	56	70	90
	64	70	90
	70	70	90

GLASS TYPES		G1	
		ALLOWABLE PRESSURE	
D.L.O. HEIGHT (in)	D.L.O. WIDTH (in)	(+) P.S.F.	(-) P.S.F.
46-3/4	24	70	90
	31	70	90
	38 3/4	70	90
	42	70	90
	48	70	90
	50 3/4	70	90
	56	70	90
	64	70	90
	70	70	90
54	24	70	90
	31	70	90
	38 3/4	70	90
	42	70	90
	48	70	90
	50 3/4	70	90
	56	65	84
	64	65	84
	70	65	84
60	24	70	90
	31	70	90
	38 3/4	70	90
	42	70	90
	48	70	90
	50 3/4	70	90
	56	63	81
	64	59	76
	70	59	76
66	24	70	90
	31	70	90
	38 3/4	70	90
	42	70	90
	48	70	90
	50 3/4	70	90
	56	63	81
	64	55	71
	70	53	69

GLASS TYPES		G1	
		ALLOWABLE PRESSURE	
D.L.O. HEIGHT (in)	D.L.O. WIDTH (in)	(+) P.S.F.	(-) P.S.F.
72	24	70	90
	31	70	90
	38 3/4	70	90
	42	70	90
	48	70	90
	50 3/4	70	90
	56	63	81
	64	55	71
	70	55	71
78	24	70	90
	31	70	90
	38 3/4	70	90
	42	70	90
	48	70	90
	50 3/4	70	90
	56	63	81
	64	63	81
	70	63	81
84	24	70	90
	31	70	90
	38 3/4	70	90
	42	70	90
	48	70	90
	50 3/4	70	90
	56	63	81
	64	63	81
	70	63	81
90	24	70	90
	31	70	90
	38 3/4	70	90
	42	70	90
	48	70	90
	50 3/4	70	90
	56	70	90
	64	70	90
	70	70	90
93	24	70	90
	31	70	90
	38 3/4	70	90
	42	70	90
	48	70	90
	50 3/4	70	90
	56	70	90
	64	70	90
	70	70	90

NOTE: D.L.O. WIDTH AND HEIGHT DIMENSIONS CAN BE REVERSED.

FRANK BENNARDO, P.E.
PE# 0046549 CA. 9885

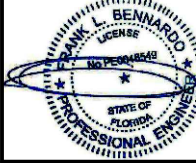

04/19/2021

FL# 38522.1

ENGINEERING EXPRESS
CORPORATE OFFICE:
160 SW 12th AVE, SUITE 106
DEERFIELD BEACH, FL 33442
(954) 354-0660 | (866) 396-9999
TEAM@ENGINEERINGEXPRESS.COM
ENGINEERINGEXPRESS.COM

GRAHAM ARCHITECTURAL PRODUCTS
1551 MT. ROSE AVENUE | YORK, PA 17403
PH: (717) 849-8100
SERIES GT6700 FIXED
FLORIDA STATEWIDE APPROVAL
FLORIDA BUILDING CODE 7TH EDITION (2020)

REMARKS	DRWN	CHKD	DATE
FBC 2020 UPDATE	TAE	AJP	04/01/21

COPYRIGHT ENGINEERING EXPRESS®

21-38803

SCALE: NTS UNLESS NOTED

04

C:\Users\lthayer\appdata\local\temp\AcPublish_11424\21-38803 GT6700 Fixed (2020 FSA).dwg

lthayer

04/19/2021 - 6:29pm

FRAME LOADING TABLES - FIXED

FIXED WINDOW ALLOWABLE PRESSURES			
FRAME WIDTH (in)	FRAME HEIGHT (in)	(+) P.S.F.	(-) P.S.F.
36	24	70	90
	30	70	90
	36	70	90
	42	70	90
	48	70	90
	54	70	90
	60	70	90
	66	70	90
	72	70	90
	78	70	90
42	24	70	90
	30	70	90
	36	70	90
	42	70	90
	48	70	90
	54	70	90
	60	70	90
	66	70	90
	72	70	90
	78	70	90
48	24	70	90
	30	70	90
	36	70	90
	42	70	90
	48	70	90
	54	70	90
	60	70	90
	66	70	90
	72	70	90
	78	70	90

FIXED WINDOW ALLOWABLE PRESSURES			
FRAME WIDTH (in)	FRAME HEIGHT (in)	(+) P.S.F.	(-) P.S.F.
54	24	70	90
	30	70	90
	36	70	90
	42	70	90
	48	70	90
	54	70	90
	60	70	90
	66	70	90
	72	70	90
	78	70	90
60	24	70	90
	30	70	90
	36	70	90
	42	70	90
	48	70	90
	54	70	90
	60	63	81
	66	63	81
	72	63	81
	78	63	81
66	24	70	90
	30	70	90
	36	70	90
	42	70	90
	48	70	90
	54	70	90
	60	63	81
	66	57	73
	72	57	73
	78	57	73

FIXED WINDOW ALLOWABLE PRESSURES				
FRAME WIDTH (in)	FRAME HEIGHT (in)	(+) P.S.F.	(-) P.S.F.	
72	24	70	90	
	30	70	90	
	36	70	90	
	42	70	90	
	48	70	90	
	54	70	90	
	60	63	81	
	66	57	73	
	72	52	67	
	78	24	70	90
78	30	70	90	
	36	70	90	
	42	70	90	
	48	70	90	
	54	70	90	
	60	63	81	
	66	57	73	
	72	24	70	90
	30	70	90	
	36	70	90	
84	42	70	90	
	48	61	78	
	54	54	70	
	60	63	81	
	66	24	70	90
	72	24	70	90
	30	70	90	
	36	70	90	
	42	70	90	
	48	70	90	
90	54	70	90	
	60	24	70	90
	66	24	70	90
	72	24	70	90
	30	70	90	
	36	70	90	
	42	70	90	
	48	70	90	
	54	70	90	
	60	24	70	90
96	30	70	90	
	36	70	90	
	42	70	90	
	48	70	90	
	54	70	90	

FRANK BENNARDO, P.E.
PE# 0046549 CA. 9885

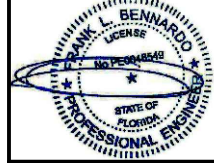

04/19/2021

FL# 38522.1

ENGINEERING EXPRESS
CORPORATE OFFICE:
160 SW 12th AVE, SUITE 106
DEERFIELD BEACH, FL 33442
(954) 354-0660 | (866) 396-9999
TEAM@ENGINEERINGEXPRESS.COM
ENGINEERINGEXPRESS.COM

GRAHAM ARCHITECTURAL PRODUCTS
1551 MT. ROSE AVENUE | YORK, PA 17403
PH: (717) 849-8100
SERIES GT6700 FIXED
FLORIDA STATEWIDE APPROVAL
FLORIDA BUILDING CODE 7TH EDITION (2020)

REMARKS	DRWN	CHKD	DATE
FBC 2020 UPDATE	TAE	AJP	04/01/21

COPYRIGHT ENGINEERING EXPRESS®

21-38803

SCALE: NTS UNLESS NOTED

FRAME LOADING TABLES - FIXED w/INTERMEDIATE HORIZONTAL

FIXED WINDOW w/INTERMEDIATE HORIZONTAL ALLOWABLE PRESSURES			
FRAME WIDTH (in)	FRAME HEIGHT (in)	(+) P.S.F.	(-) P.S.F.
36	24	70	90
	30	70	90
	36	70	90
	42	70	90
	48	70	90
	54	70	90
	60	70	90
	66	70	90
	72	70	90
	78	70	90
42	24	70	90
	30	70	90
	36	70	90
	42	70	90
	48	70	90
	54	70	90
	60	70	90
	66	70	90
	72	70	90
	78	70	90
48	24	70	90
	30	70	90
	36	70	90
	42	70	90
	48	61	78
	54	61	78
	60	61	78
	66	61	78
	72	61	78
	78	61	78

FIXED WINDOW w/INTERMEDIATE HORIZONTAL ALLOWABLE PRESSURES				
FRAME WIDTH (in)	FRAME HEIGHT (in)	(+) P.S.F.	(-) P.S.F.	
54	24	70	90	
	30	70	90	
	36	70	90	
	42	70	90	
	48	61	78	
	54	54	70	
	60	54	70	
	66	54	70	
	72	54	70	
	60	24	70	90
30		70	90	
36		70	90	
42		70	90	
48		61	78	
54		54	70	
60		49	63	
66		49	63	
66		24	70	90
		30	70	90
	36	70	90	
	42	70	90	
	48	61	78	
	54	54	70	
	60	49	63	
	72	24	70	90
		30	70	90
		36	70	90
42		70	90	
48		61	78	
54		54	70	

FIXED WINDOW w/INTERMEDIATE HORIZONTAL ALLOWABLE PRESSURES			
FRAME WIDTH (in)	FRAME HEIGHT (in)	(+) P.S.F.	(-) P.S.F.
78	24	70	90
	30	70	90
	36	70	90
	42	70	90
	48	61	78
84	24	70	90
	30	70	90
	36	70	90
	42	70	90
	48	61	78
90	24	70	90
	30	70	90
	36	70	90
	42	70	90
	48	61	78
96	24	70	90
	30	70	90
	36	70	90
	42	70	90
	48	61	78
99	24	70	90
	30	70	90
	36	70	90
	42	70	90

FRANK BENNARDO, P.E.
PE# 0046549 CA. 9885

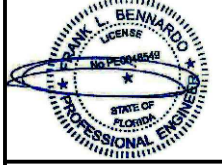

04/19/2021

FL# 38522.1

ENGINEERING EXPRESS
CORPORATE OFFICE:
160 SW 12th AVE, SUITE 106
DEERFIELD BEACH, FL 33442
(954) 354-0660 | (866) 396-9999
TEAM@ENGINEERINGEXPRESS.COM
ENGINEERINGEXPRESS.COM

GRAHAM ARCHITECTURAL PRODUCTS
1551 MT. ROSE AVENUE | YORK, PA 17403
PH: (717) 849-8100

SERIES GT6700 FIXED
FLORIDA STATEWIDE APPROVAL
FLORIDA BUILDING CODE 7TH EDITION (2020)

REMARKS	DRWN	CHKD	DATE
FBC 2020 UPDATE	TAE	AJP	04/01/21

COPYRIGHT ENGINEERING EXPRESS®

21-38803

SCALE: NTS UNLESS NOTED

16

06

C:\Users\lthayer\appdata\local\temp\AcPublish_11424\21-38803 GT6700 Fixed (2020 FSA).dwg
lthayer
04/19/2021 - 6:29pm

FASTENER SCHEDULE

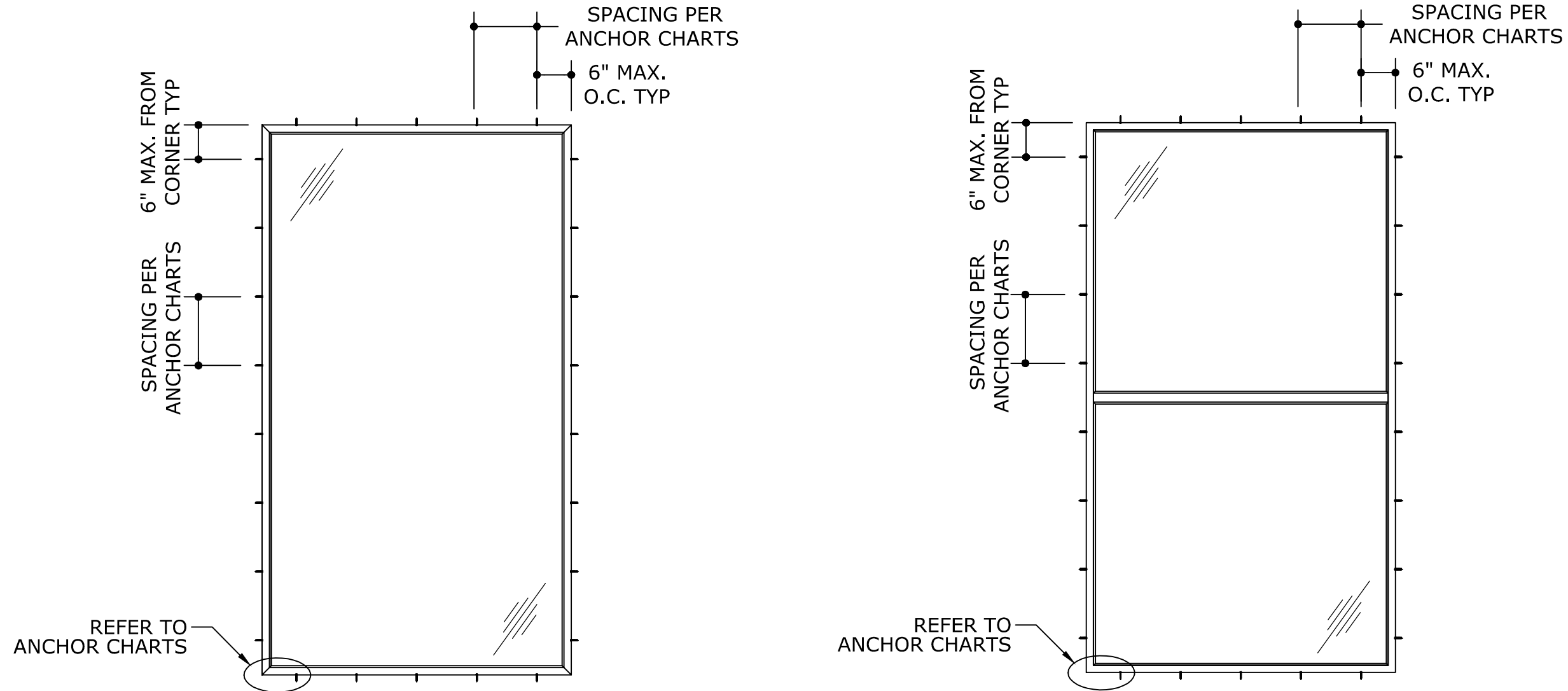

ANCHOR SCHEDULE					
ANCHOR TYPE	ANCHOR DIAMETER	TYPE	SUBSTRATE	MIN. EMBEDMENT (IN)	MIN. EDGE DISTANCE (IN)
A	3/16"	TAPCON	POURED CONCRETE 3000 PSI MIN	1-1/4	2-1/2
B	#10-16	SELF DRILLING SCREW	16 GA. MIN. STUD ASTM A-653 GRADE 33 STEEL	3 PINCHES PASSED THREAD PLANE	1/2
			1/8" STEEL-A36 1/8" ALUMINUM-6063-T6		
C	#10	WOOD SCREW	2X WOOD BUCK (SYP#2 MIN.) G=0.55	1-1/2	3/4

FRANK BENNARDO, P.E.
PE# 0046549 CA. 9885

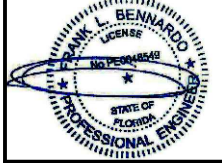

04/19/2021

FL# 38522.1

ENGINEERING EXPRESS
CORPORATE OFFICE:
160 SW 12th AVE, SUITE 106
DEERFIELD BEACH, FL 33442
(954) 354-0660 | (866) 396-9999
TEAM@ENGINEERINGEXPRESS.COM
ENGINEERINGEXPRESS.COM

GRAHAM ARCHITECTURAL PRODUCTS
1551 MT. ROSE AVENUE | YORK, PA 17403
PH: (717) 849-8100

SERIES GT6700 FIXED
FLORIDA STATEWIDE APPROVAL
FLORIDA BUILDING CODE 7TH EDITION (2020)

DRWN	CHKD	DATE
TAE	AJP	04/01/21

REMARKS
FBC 2020 UPDATE

COPYRIGHT ENGINEERING EXPRESS®

21-38803

SCALE: NTS UNLESS NOTED

07

C:\Users\thayer\appdata\local\temp\AcPublish_1142421-38803 GT6700 Fixed (2020 FSA).dwg

thayer

04/19/2021 - 6:29pm

ANCHOR CHARTS

FRAME HEIGHT (IN)	FRAME WIDTH (IN)	TYPE A (CONCRETE) DESIGN PRESSURE = 90 PSF		TYPE B (METAL) DESIGN PRESSURE = 90 PSF		TYPE C (WOOD) DESIGN PRESSURE = 90 PSF	
		HEAD/SILL MAX ANCHOR SPACING (IN)	JAMBS MAX ANCHOR SPACING (IN)	HEAD/SILL MAX ANCHOR SPACING (IN)	JAMBS MAX ANCHOR SPACING (IN)	HEAD/SILL MAX ANCHOR SPACING (IN)	JAMBS MAX ANCHOR SPACING (IN)
24	24	24 O.C.	29 O.C.	25 O.C.	30 O.C.	22 O.C.	27 O.C.
	30	24 O.C.	24 O.C.	25 O.C.	25 O.C.	22 O.C.	22 O.C.
	36	24 O.C.	21 O.C.	25 O.C.	22 O.C.	22 O.C.	19 O.C.
	42	24 O.C.	19 O.C.	25 O.C.	20 O.C.	22 O.C.	17 O.C.
	48	24 O.C.	18 O.C.	25 O.C.	18 O.C.	22 O.C.	16 O.C.
	54	24 O.C.	17 O.C.	25 O.C.	17 O.C.	22 O.C.	15 O.C.
	60	24 O.C.	16 O.C.	25 O.C.	16 O.C.	22 O.C.	14 O.C.
	63	24 O.C.	16 O.C.	25 O.C.	16 O.C.	22 O.C.	14 O.C.
	66	24 O.C.	16 O.C.	25 O.C.	16 O.C.	22 O.C.	14 O.C.
	78	24 O.C.	15 O.C.	25 O.C.	16 O.C.	22 O.C.	13 O.C.
30	24	19 O.C.	29 O.C.	20 O.C.	30 O.C.	17 O.C.	27 O.C.
	30	19 O.C.	24 O.C.	20 O.C.	25 O.C.	17 O.C.	22 O.C.
	36	19 O.C.	21 O.C.	20 O.C.	22 O.C.	17 O.C.	19 O.C.
	42	19 O.C.	19 O.C.	20 O.C.	20 O.C.	17 O.C.	17 O.C.
	48	19 O.C.	18 O.C.	20 O.C.	18 O.C.	17 O.C.	16 O.C.
	54	19 O.C.	17 O.C.	20 O.C.	17 O.C.	17 O.C.	15 O.C.
	60	19 O.C.	16 O.C.	20 O.C.	16 O.C.	17 O.C.	14 O.C.
	63	19 O.C.	16 O.C.	20 O.C.	16 O.C.	17 O.C.	14 O.C.
	66	19 O.C.	16 O.C.	20 O.C.	16 O.C.	17 O.C.	14 O.C.
	78	19 O.C.	15 O.C.	20 O.C.	16 O.C.	17 O.C.	13 O.C.
36	24	16 O.C.	29 O.C.	17 O.C.	30 O.C.	14 O.C.	27 O.C.
	30	16 O.C.	24 O.C.	17 O.C.	25 O.C.	14 O.C.	22 O.C.
	36	16 O.C.	21 O.C.	17 O.C.	22 O.C.	14 O.C.	19 O.C.
	42	16 O.C.	19 O.C.	17 O.C.	20 O.C.	14 O.C.	17 O.C.
	48	16 O.C.	18 O.C.	17 O.C.	18 O.C.	14 O.C.	16 O.C.
	54	16 O.C.	17 O.C.	17 O.C.	17 O.C.	14 O.C.	15 O.C.
	60	16 O.C.	16 O.C.	17 O.C.	16 O.C.	14 O.C.	14 O.C.
	63	16 O.C.	16 O.C.	17 O.C.	16 O.C.	14 O.C.	14 O.C.
	66	16 O.C.	16 O.C.	17 O.C.	16 O.C.	14 O.C.	14 O.C.
	78	16 O.C.	15 O.C.	17 O.C.	16 O.C.	14 O.C.	13 O.C.

FRAME HEIGHT (IN)	FRAME WIDTH (IN)	TYPE A (CONCRETE) DESIGN PRESSURE = 90 PSF		TYPE B (METAL) DESIGN PRESSURE = 90 PSF		TYPE C (WOOD) DESIGN PRESSURE = 90 PSF	
		HEAD/SILL MAX ANCHOR SPACING (IN)	JAMBS MAX ANCHOR SPACING (IN)	HEAD/SILL MAX ANCHOR SPACING (IN)	JAMBS MAX ANCHOR SPACING (IN)	HEAD/SILL MAX ANCHOR SPACING (IN)	JAMBS MAX ANCHOR SPACING (IN)
42	24	14 O.C.	29 O.C.	14 O.C.	30 O.C.	12 O.C.	27 O.C.
	30	14 O.C.	24 O.C.	14 O.C.	25 O.C.	12 O.C.	22 O.C.
	36	14 O.C.	21 O.C.	14 O.C.	22 O.C.	12 O.C.	19 O.C.
	42	14 O.C.	19 O.C.	14 O.C.	20 O.C.	12 O.C.	17 O.C.
	48	14 O.C.	18 O.C.	14 O.C.	18 O.C.	12 O.C.	16 O.C.
	54	14 O.C.	17 O.C.	14 O.C.	17 O.C.	12 O.C.	15 O.C.
	60	14 O.C.	16 O.C.	14 O.C.	16 O.C.	12 O.C.	14 O.C.
	63	14 O.C.	16 O.C.	14 O.C.	16 O.C.	12 O.C.	14 O.C.
	66	14 O.C.	16 O.C.	14 O.C.	16 O.C.	12 O.C.	14 O.C.
	78	14 O.C.	15 O.C.	14 O.C.	16 O.C.	12 O.C.	13 O.C.
48	24	14 O.C.	29 O.C.	13 O.C.	30 O.C.	12 O.C.	27 O.C.
	30	14 O.C.	24 O.C.	13 O.C.	25 O.C.	12 O.C.	22 O.C.
	36	12 O.C.	21 O.C.	13 O.C.	22 O.C.	10 O.C.	19 O.C.
	42	12 O.C.	19 O.C.	13 O.C.	20 O.C.	10 O.C.	17 O.C.
	48	12 O.C.	18 O.C.	13 O.C.	18 O.C.	10 O.C.	16 O.C.
	54	12 O.C.	17 O.C.	13 O.C.	17 O.C.	10 O.C.	15 O.C.
	60	12 O.C.	16 O.C.	13 O.C.	16 O.C.	10 O.C.	14 O.C.
	63	12 O.C.	16 O.C.	13 O.C.	16 O.C.	10 O.C.	14 O.C.
	66	12 O.C.	16 O.C.	13 O.C.	16 O.C.	10 O.C.	14 O.C.
	78	12 O.C.	15 O.C.	13 O.C.	16 O.C.	10 O.C.	13 O.C.
54	24	14 O.C.	29 O.C.	16 O.C.	30 O.C.	12 O.C.	27 O.C.
	30	14 O.C.	24 O.C.	16 O.C.	25 O.C.	12 O.C.	22 O.C.
	36	12 O.C.	21 O.C.	13 O.C.	22 O.C.	10 O.C.	19 O.C.
	42	12 O.C.	19 O.C.	13 O.C.	20 O.C.	10 O.C.	17 O.C.
	48	12 O.C.	18 O.C.	13 O.C.	18 O.C.	10 O.C.	16 O.C.
	54	12 O.C.	17 O.C.	13 O.C.	17 O.C.	10 O.C.	15 O.C.
	60	12 O.C.	16 O.C.	13 O.C.	16 O.C.	10 O.C.	14 O.C.
	63	12 O.C.	16 O.C.	13 O.C.	16 O.C.	10 O.C.	14 O.C.
	66	12 O.C.	16 O.C.	13 O.C.	16 O.C.	10 O.C.	14 O.C.
	78	12 O.C.	15 O.C.	13 O.C.	16 O.C.	10 O.C.	13 O.C.

FRANK BENNARDO, P.E.
PE# 0046549 CA. 9885

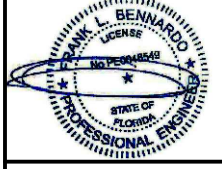

04/19/2021

FL# 38522.1

ENGINEERING EXPRESS
CORPORATE OFFICE:
160 SW 12th AVE, SUITE 106
DEERFIELD BEACH, FL 33442
(954) 354-0660 | (866) 396-9999
TEAM@ENGINEERINGEXPRESS.COM
ENGINEERINGEXPRESS.COM

GRAHAM ARCHITECTURAL PRODUCTS
1551 MT. ROSE AVENUE | YORK, PA 17403
PH: (717) 849-8100

SERIES GT6700 FIXED
FLORIDA STATEWIDE APPROVAL
FLORIDA BUILDING CODE 7TH EDITION (2020)

REMARKS	DRWN	CHKD	DATE
FBC 2020 UPDATE	TAE	AJP	04/01/21

21-38803

SCALE: NTS UNLESS NOTED

08

ANCHOR CHARTS

FRAME HEIGHT (IN)	FRAME WIDTH (IN)	TYPE A (CONCRETE) DESIGN PRESSURE = 90 PSF		TYPE B (METAL) DESIGN PRESSURE = 90 PSF		TYPE C (WOOD) DESIGN PRESSURE = 90 PSF	
		HEAD/SILL MAX ANCHOR SPACING (IN)	JAMBS MAX ANCHOR SPACING (IN)	HEAD/SILL MAX ANCHOR SPACING (IN)	JAMBS MAX ANCHOR SPACING (IN)	HEAD/SILL MAX ANCHOR SPACING (IN)	JAMBS MAX ANCHOR SPACING (IN)
60	24	14 O.C.	29 O.C.	16 O.C.	30 O.C.	12 O.C.	27 O.C.
	30	14 O.C.	24 O.C.	16 O.C.	25 O.C.	12 O.C.	22 O.C.
	36	12 O.C.	21 O.C.	13 O.C.	22 O.C.	10 O.C.	19 O.C.
	42	12 O.C.	19 O.C.	13 O.C.	20 O.C.	10 O.C.	17 O.C.
	48	12 O.C.	18 O.C.	13 O.C.	18 O.C.	10 O.C.	16 O.C.
	54	12 O.C.	17 O.C.	13 O.C.	17 O.C.	10 O.C.	15 O.C.
	60	12 O.C.	16 O.C.	13 O.C.	16 O.C.	10 O.C.	14 O.C.
	63	12 O.C.	16 O.C.	13 O.C.	16 O.C.	10 O.C.	14 O.C.
	66	12 O.C.	16 O.C.	13 O.C.	16 O.C.	10 O.C.	14 O.C.
	78	12 O.C.	15 O.C.	13 O.C.	16 O.C.	10 O.C.	13 O.C.
63	24	14 O.C.	29 O.C.	16 O.C.	30 O.C.	12 O.C.	27 O.C.
	30	14 O.C.	24 O.C.	16 O.C.	25 O.C.	12 O.C.	22 O.C.
	36	12 O.C.	21 O.C.	13 O.C.	22 O.C.	10 O.C.	19 O.C.
	42	12 O.C.	19 O.C.	13 O.C.	20 O.C.	10 O.C.	17 O.C.
	48	12 O.C.	18 O.C.	13 O.C.	18 O.C.	10 O.C.	16 O.C.
	54	12 O.C.	17 O.C.	13 O.C.	17 O.C.	10 O.C.	15 O.C.
	60	12 O.C.	16 O.C.	13 O.C.	16 O.C.	10 O.C.	14 O.C.
	63	12 O.C.	16 O.C.	13 O.C.	16 O.C.	10 O.C.	14 O.C.
	66	12 O.C.	16 O.C.	13 O.C.	16 O.C.	10 O.C.	14 O.C.
	78	12 O.C.	15 O.C.	13 O.C.	16 O.C.	10 O.C.	13 O.C.
66	24	14 O.C.	29 O.C.	16 O.C.	30 O.C.	12 O.C.	27 O.C.
	30	14 O.C.	24 O.C.	16 O.C.	25 O.C.	12 O.C.	22 O.C.
	36	12 O.C.	21 O.C.	13 O.C.	22 O.C.	10 O.C.	19 O.C.
	42	12 O.C.	19 O.C.	13 O.C.	20 O.C.	10 O.C.	17 O.C.
	48	12 O.C.	18 O.C.	13 O.C.	18 O.C.	10 O.C.	16 O.C.
	54	12 O.C.	17 O.C.	13 O.C.	17 O.C.	10 O.C.	15 O.C.
	60	12 O.C.	16 O.C.	13 O.C.	16 O.C.	10 O.C.	14 O.C.
	63	12 O.C.	16 O.C.	13 O.C.	16 O.C.	10 O.C.	14 O.C.
	66	12 O.C.	16 O.C.	13 O.C.	16 O.C.	10 O.C.	14 O.C.
	78	12 O.C.	15 O.C.	13 O.C.	16 O.C.	10 O.C.	13 O.C.

FRAME HEIGHT (IN)	FRAME WIDTH (IN)	TYPE A (CONCRETE) DESIGN PRESSURE = 90 PSF		TYPE B (METAL) DESIGN PRESSURE = 90 PSF		TYPE C (WOOD) DESIGN PRESSURE = 90 PSF	
		HEAD/SILL MAX ANCHOR SPACING (IN)	JAMBS MAX ANCHOR SPACING (IN)	HEAD/SILL MAX ANCHOR SPACING (IN)	JAMBS MAX ANCHOR SPACING (IN)	HEAD/SILL MAX ANCHOR SPACING (IN)	JAMBS MAX ANCHOR SPACING (IN)
72	24	14 O.C.	29 O.C.	16 O.C.	30 O.C.	12 O.C.	27 O.C.
	30	14 O.C.	24 O.C.	16 O.C.	25 O.C.	12 O.C.	22 O.C.
	36	12 O.C.	21 O.C.	13 O.C.	22 O.C.	10 O.C.	19 O.C.
	42	12 O.C.	19 O.C.	13 O.C.	20 O.C.	10 O.C.	17 O.C.
	48	12 O.C.	18 O.C.	13 O.C.	18 O.C.	10 O.C.	16 O.C.
	54	12 O.C.	17 O.C.	13 O.C.	17 O.C.	10 O.C.	15 O.C.
	60	12 O.C.	16 O.C.	13 O.C.	16 O.C.	10 O.C.	14 O.C.
	63	12 O.C.	16 O.C.	13 O.C.	16 O.C.	10 O.C.	14 O.C.
	66	12 O.C.	16 O.C.	13 O.C.	16 O.C.	10 O.C.	14 O.C.
	78	12 O.C.	15 O.C.	13 O.C.	16 O.C.	10 O.C.	13 O.C.
75	24	14 O.C.	29 O.C.	16 O.C.	30 O.C.	12 O.C.	27 O.C.
	30	14 O.C.	24 O.C.	16 O.C.	25 O.C.	12 O.C.	22 O.C.
	36	12 O.C.	21 O.C.	13 O.C.	22 O.C.	10 O.C.	19 O.C.
	42	12 O.C.	19 O.C.	13 O.C.	20 O.C.	10 O.C.	17 O.C.
	48	12 O.C.	18 O.C.	13 O.C.	18 O.C.	10 O.C.	16 O.C.
	54	12 O.C.	17 O.C.	13 O.C.	17 O.C.	10 O.C.	15 O.C.
	60	12 O.C.	16 O.C.	13 O.C.	16 O.C.	10 O.C.	14 O.C.
	63	12 O.C.	16 O.C.	13 O.C.	16 O.C.	10 O.C.	14 O.C.
	66	12 O.C.	16 O.C.	13 O.C.	16 O.C.	10 O.C.	14 O.C.
	78	12 O.C.	15 O.C.	13 O.C.	16 O.C.	10 O.C.	13 O.C.
78	24	14 O.C.	28 O.C.	16 O.C.	30 O.C.	12 O.C.	26 O.C.
	30	14 O.C.	24 O.C.	16 O.C.	25 O.C.	12 O.C.	22 O.C.
	36	12 O.C.	21 O.C.	13 O.C.	22 O.C.	10 O.C.	19 O.C.
	42	12 O.C.	19 O.C.	13 O.C.	20 O.C.	10 O.C.	17 O.C.
	48	12 O.C.	17 O.C.	13 O.C.	18 O.C.	10 O.C.	15 O.C.
	54	12 O.C.	16 O.C.	13 O.C.	17 O.C.	10 O.C.	14 O.C.
	60	12 O.C.	16 O.C.	13 O.C.	16 O.C.	10 O.C.	14 O.C.
	63	12 O.C.	15 O.C.	13 O.C.	16 O.C.	10 O.C.	13 O.C.
	66	12 O.C.	15 O.C.	13 O.C.	16 O.C.	10 O.C.	13 O.C.
	78	12 O.C.	15 O.C.	13 O.C.	16 O.C.	10 O.C.	13 O.C.

FRANK BENNARDO, P.E.
PE# 0046549 CA. 9885

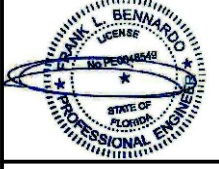

04/19/2021

FL# 38522.1

ENGINEERING EXPRESS
CORPORATE OFFICE:
160 SW 12th AVE, SUITE 106
DEERFIELD BEACH, FL 33442
(954) 354-0660 | (866) 396-9999
TEAM@ENGINEERINGEXPRESS.COM
ENGINEERINGEXPRESS.COM

GRAHAM ARCHITECTURAL PRODUCTS
1551 MT. ROSE AVENUE | YORK, PA 17403
PH: (717) 849-8100
SERIES GT6700 FIXED
FLORIDA STATEWIDE APPROVAL
FLORIDA BUILDING CODE 7TH EDITION (2020)

REMARKS	DRWN	CHKD	DATE
FBC 2020 UPDATE	TAE	AJP	04/01/21

COPYRIGHT ENGINEERING EXPRESS®

21-38803

SCALE: NTS UNLESS NOTED

16

09

ANCHOR CHARTS

FRAME HEIGHT (IN)	FRAME WIDTH (IN)	TYPE A (CONCRETE) DESIGN PRESSURE = 90 PSF		TYPE B (METAL) DESIGN PRESSURE = 90 PSF		TYPE C (WOOD) DESIGN PRESSURE = 90 PSF	
		HEAD/SILL MAX ANCHOR SPACING (IN)	JAMBS MAX ANCHOR SPACING (IN)	HEAD/SILL MAX ANCHOR SPACING (IN)	JAMBS MAX ANCHOR SPACING (IN)	HEAD/SILL MAX ANCHOR SPACING (IN)	JAMBS MAX ANCHOR SPACING (IN)
84	24	14 O.C.	28 O.C.	16 O.C.	30 O.C.	12 O.C.	26 O.C.
	30	14 O.C.	23 O.C.	16 O.C.	25 O.C.	12 O.C.	21 O.C.
	36	12 O.C.	20 O.C.	13 O.C.	21 O.C.	10 O.C.	18 O.C.
	42	12 O.C.	18 O.C.	13 O.C.	19 O.C.	10 O.C.	16 O.C.
	48	12 O.C.	17 O.C.	13 O.C.	18 O.C.	10 O.C.	15 O.C.
	54	12 O.C.	16 O.C.	13 O.C.	17 O.C.	10 O.C.	14 O.C.
	60	12 O.C.	15 O.C.	13 O.C.	16 O.C.	10 O.C.	13 O.C.
	63	12 O.C.	15 O.C.	13 O.C.	15 O.C.	10 O.C.	13 O.C.
	66	12 O.C.	14 O.C.	13 O.C.	15 O.C.	10 O.C.	12 O.C.
	78	12 O.C.	14 O.C.	13 O.C.	15 O.C.	10 O.C.	12 O.C.
90	24	14 O.C.	28 O.C.	16 O.C.	29 O.C.	12 O.C.	26 O.C.
	30	14 O.C.	23 O.C.	16 O.C.	24 O.C.	12 O.C.	21 O.C.
	36	12 O.C.	20 O.C.	13 O.C.	21 O.C.	10 O.C.	18 O.C.
	42	12 O.C.	18 O.C.	13 O.C.	19 O.C.	10 O.C.	16 O.C.
	48	12 O.C.	16 O.C.	13 O.C.	17 O.C.	10 O.C.	14 O.C.
	54	12 O.C.	15 O.C.	13 O.C.	16 O.C.	10 O.C.	13 O.C.
	60	12 O.C.	14 O.C.	13 O.C.	15 O.C.	10 O.C.	12 O.C.
	63	12 O.C.	14 O.C.	13 O.C.	15 O.C.	10 O.C.	12 O.C.
	66	12 O.C.	14 O.C.	13 O.C.	15 O.C.	10 O.C.	12 O.C.
	78	12 O.C.	13 O.C.	13 O.C.	14 O.C.	10 O.C.	11 O.C.

FRAME HEIGHT (IN)	FRAME WIDTH (IN)	TYPE A (CONCRETE) DESIGN PRESSURE = 90 PSF		TYPE B (METAL) DESIGN PRESSURE = 90 PSF		TYPE C (WOOD) DESIGN PRESSURE = 90 PSF	
		HEAD/SILL MAX ANCHOR SPACING (IN)	JAMBS MAX ANCHOR SPACING (IN)	HEAD/SILL MAX ANCHOR SPACING (IN)	JAMBS MAX ANCHOR SPACING (IN)	HEAD/SILL MAX ANCHOR SPACING (IN)	JAMBS MAX ANCHOR SPACING (IN)
96	24	14 O.C.	27 O.C.	16 O.C.	29 O.C.	12 O.C.	25 O.C.
	30	14 O.C.	23 O.C.	16 O.C.	24 O.C.	12 O.C.	21 O.C.
	36	12 O.C.	20 O.C.	13 O.C.	21 O.C.	10 O.C.	18 O.C.
	42	12 O.C.	18 O.C.	13 O.C.	19 O.C.	10 O.C.	16 O.C.
	48	12 O.C.	16 O.C.	13 O.C.	17 O.C.	10 O.C.	14 O.C.
	54	12 O.C.	15 O.C.	13 O.C.	16 O.C.	10 O.C.	13 O.C.
	60	12 O.C.	14 O.C.	13 O.C.	15 O.C.	10 O.C.	12 O.C.
	63	12 O.C.	14 O.C.	13 O.C.	14 O.C.	10 O.C.	12 O.C.
	66	12 O.C.	13 O.C.	13 O.C.	14 O.C.	10 O.C.	11 O.C.
	78	12 O.C.	12 O.C.	13 O.C.	13 O.C.	10 O.C.	10 O.C.
99	24	14 O.C.	27 O.C.	16 O.C.	29 O.C.	12 O.C.	25 O.C.
	30	14 O.C.	23 O.C.	16 O.C.	24 O.C.	12 O.C.	21 O.C.
	36	12 O.C.	20 O.C.	13 O.C.	21 O.C.	10 O.C.	18 O.C.
	42	12 O.C.	18 O.C.	13 O.C.	19 O.C.	10 O.C.	16 O.C.
	48	12 O.C.	16 O.C.	13 O.C.	17 O.C.	10 O.C.	14 O.C.
	54	12 O.C.	15 O.C.	13 O.C.	16 O.C.	10 O.C.	13 O.C.
	60	12 O.C.	14 O.C.	13 O.C.	15 O.C.	10 O.C.	12 O.C.
	63	12 O.C.	14 O.C.	13 O.C.	14 O.C.	10 O.C.	12 O.C.
	66	12 O.C.	13 O.C.	13 O.C.	14 O.C.	10 O.C.	11 O.C.
	78	12 O.C.	12 O.C.	13 O.C.	13 O.C.	10 O.C.	10 O.C.

FRANK BENNARDO, P.E.
PE# 0046549 CA. 9885

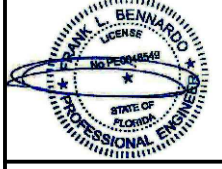

04/19/2021

FL# 38522.1

ENGINEERING EXPRESS
CORPORATE OFFICE:
160 SW 12th AVE, SUITE 106
DEERFIELD BEACH, FL 33442
(954) 354-0660 | (866) 396-9999
TEAM@ENGINEERINGEXPRESS.COM
ENGINEERINGEXPRESS.COM

GRAHAM ARCHITECTURAL PRODUCTS
1551 MT. ROSE AVENUE | YORK, PA 17403
PH: (717) 849-8100
SERIES GT6700 FIXED
FLORIDA STATEWIDE APPROVAL
FLORIDA BUILDING CODE 7TH EDITION (2020)

REMARKS	DRWN	CHKD	DATE
FBC 2020 UPDATE	TAE	AJP	04/01/21

COPYRIGHT ENGINEERING EXPRESS®

21-38803

SCALE: NTS UNLESS NOTED

HEAD DETAILS

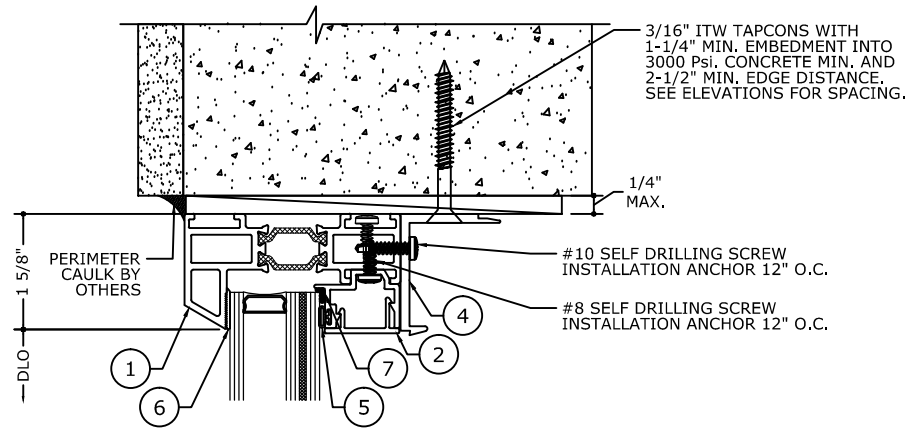

1 HEAD DETAIL
PRE-SET PANNING
SCREW APPLIED BEAD

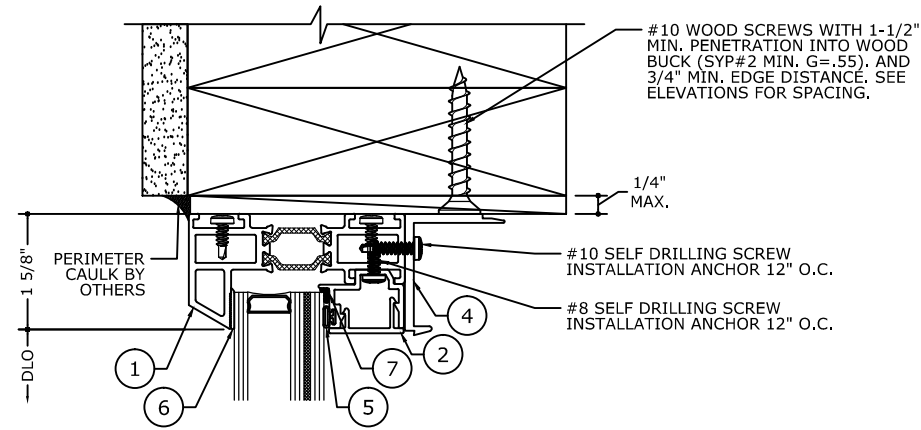

1.1 HEAD DETAIL
PRE-SET PANNING
SCREW APPLIED BEAD

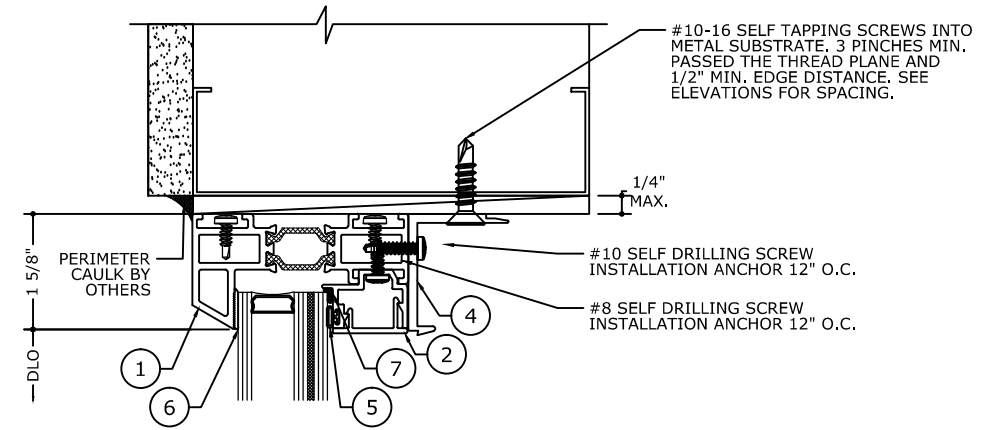

1.2 HEAD DETAIL
PRE-SET PANNING
SCREW APPLIED BEAD

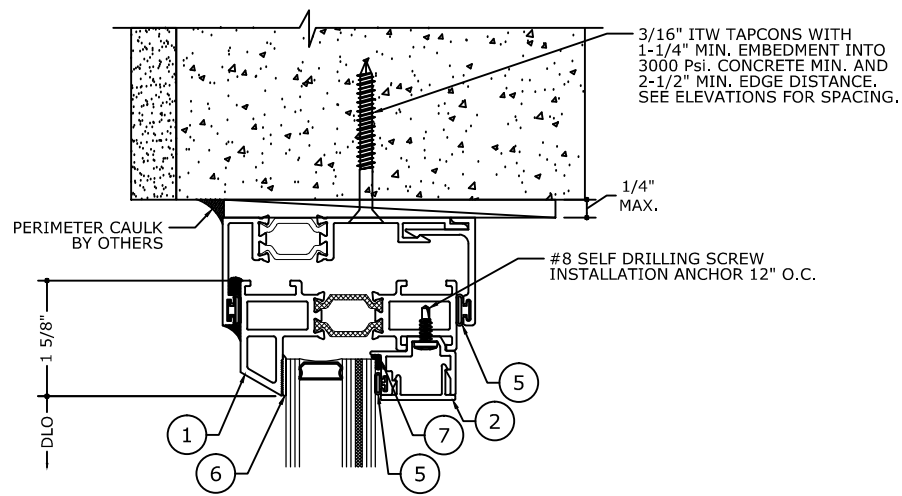

1.3 HEAD DETAIL
RECEPTOR

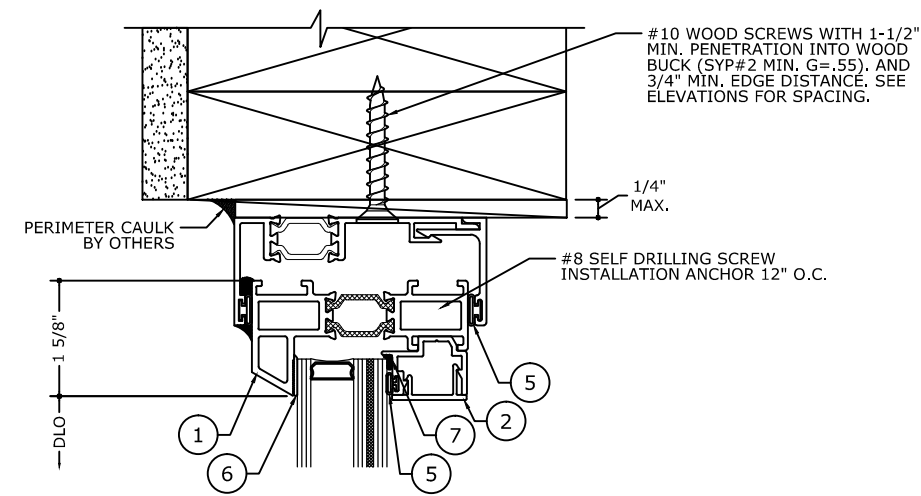

1.4 HEAD DETAIL
RECEPTOR

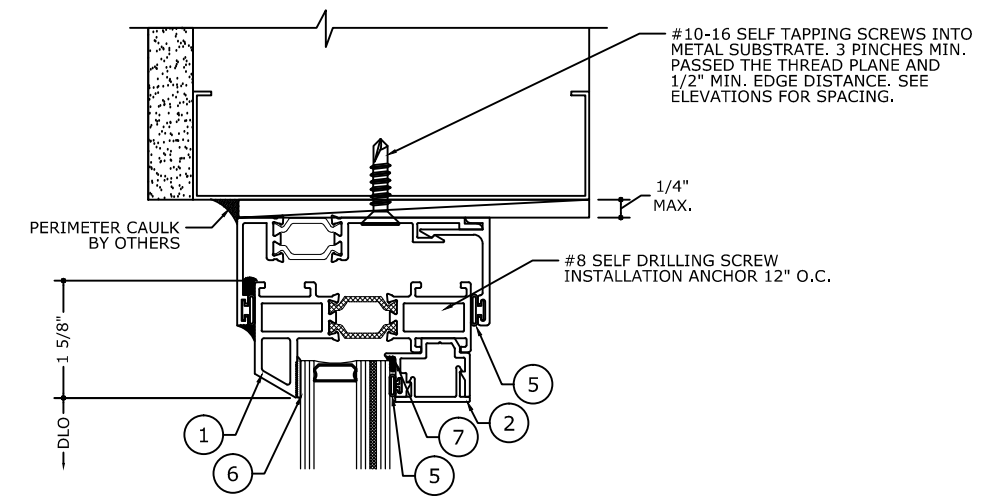

1.5 HEAD DETAIL
RECEPTOR

NOTE: REFER TO SYSTEM INSTALLATION MANUAL FOR FABRICATION AND ASSEMBLY INSTRUCTIONS.

FRANK BENNARDO, P.E.
PE# 0046549 CA. 9885

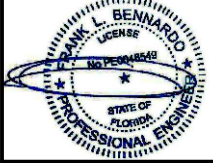

04/19/2021

FL# 38522.1

ENGINEERING EXPRESS
CORPORATE OFFICE:
160 SW 12th AVE, SUITE 106
DEERFIELD BEACH, FL 33442
(954) 354-0660 | (866) 396-9999
TEAM@ENGINEERINGEXPRESS.COM
ENGINEERINGEXPRESS.COM

GRAHAM ARCHITECTURAL PRODUCTS
1551 MT. ROSE AVENUE | YORK, PA 17403
PH: (717) 849-8100
SERIES GT6700 FIXED
FLORIDA STATEWIDE APPROVAL
FLORIDA BUILDING CODE 7TH EDITION (2020)

REMARKS	DRWN	CHKD	DATE
FBC 2020 UPDATE	TAE	AJP	04/01/21

COPYRIGHT ENGINEERING EXPRESS®
21-38803

SCALE: NTS UNLESS NOTED

C:\Users\thayer\appdata\local\temp\AcPublish_11424\21-38803 GT6700 Fixed (2020 FSA).dwg
thayer
04/19/2021 - 6:29pm

INTERMEDIATE HORIZONTAL DETAILS

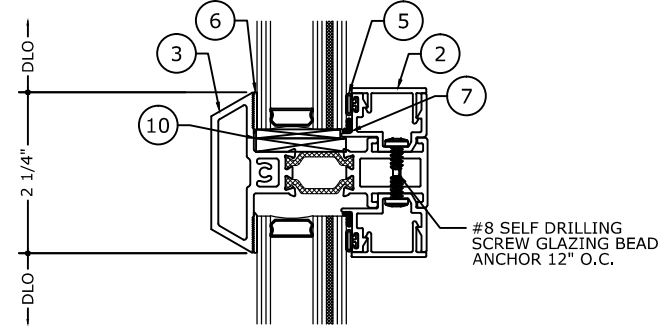

2 INTERMEDIATE DETAIL

FRANK BENNARDO, P.E.
PE# 0046549 CA. 9885

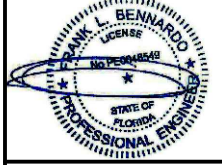

04/19/2021

FL# 38522.1

ENGINEERING EXPRESS®
CORPORATE OFFICE:
160 SW 12th AVE, SUITE 106
DEERFIELD BEACH, FL 33442
(954) 354-0660 | (866) 396-9999
TEAM@ENGINEERINGEXPRESS.COM
ENGINEERINGEXPRESS.COM

GRAHAM ARCHITECTURAL PRODUCTS
1551 MT. ROSE AVENUE | YORK, PA 17403
PH: (717) 849-8100

SERIES GT6700 FIXED
FLORIDA STATEWIDE APPROVAL
FLORIDA BUILDING CODE 7TH EDITION (2020)

REMARKS	DRWN	CHKD	DATE
FBC 2020 UPDATE	TAE	AJP	04/01/21
	-	-	-
	-	-	-
	-	-	-

COPYRIGHT ENGINEERING EXPRESS®

21-38803

SCALE: NTS UNLESS NOTED

SILL DETAILS

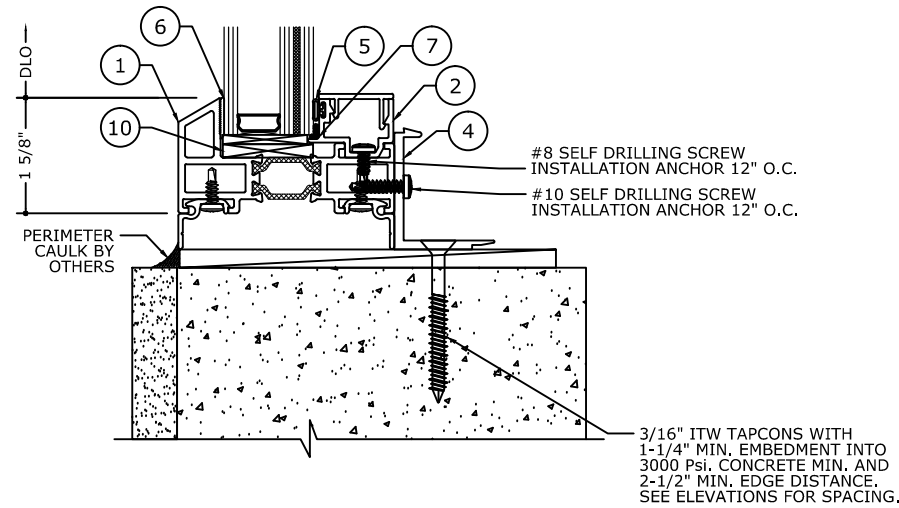

3 SILL DETAIL
PRE-SET PANNING
SCREW APPLIED BEAD

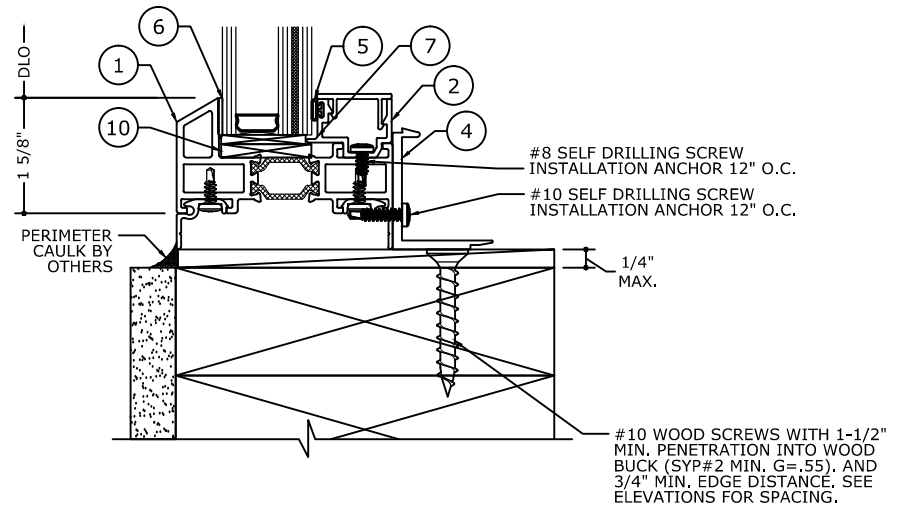

3.1 SILL DETAIL
PRE-SET PANNING
SCREW APPLIED BEAD

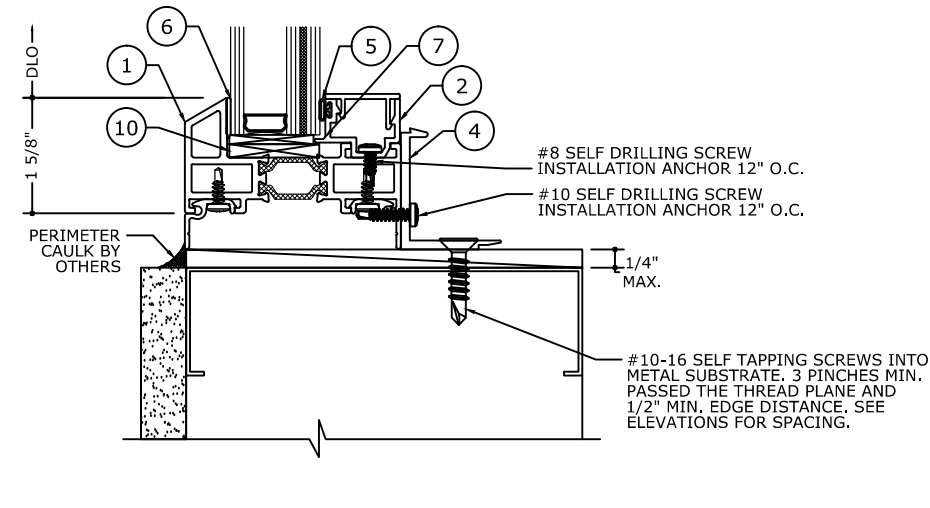

3.2 SILL DETAIL
PRE-SET PANNING
SCREW APPLIED BEAD

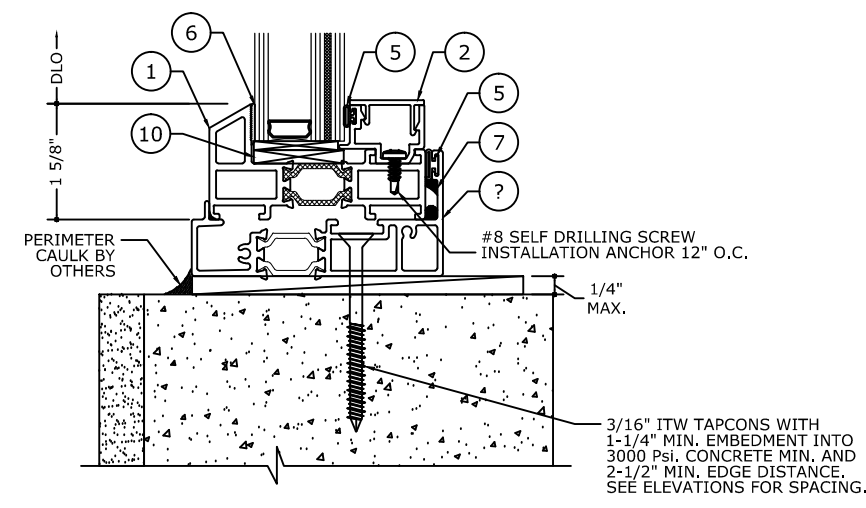

3.3 SILL DETAIL
RECEPTOR

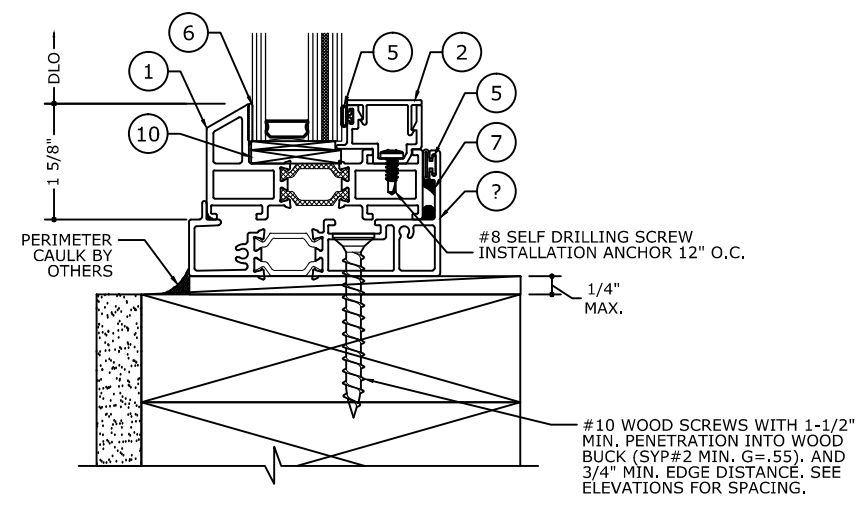

3.4 SILL DETAIL
RECEPTOR

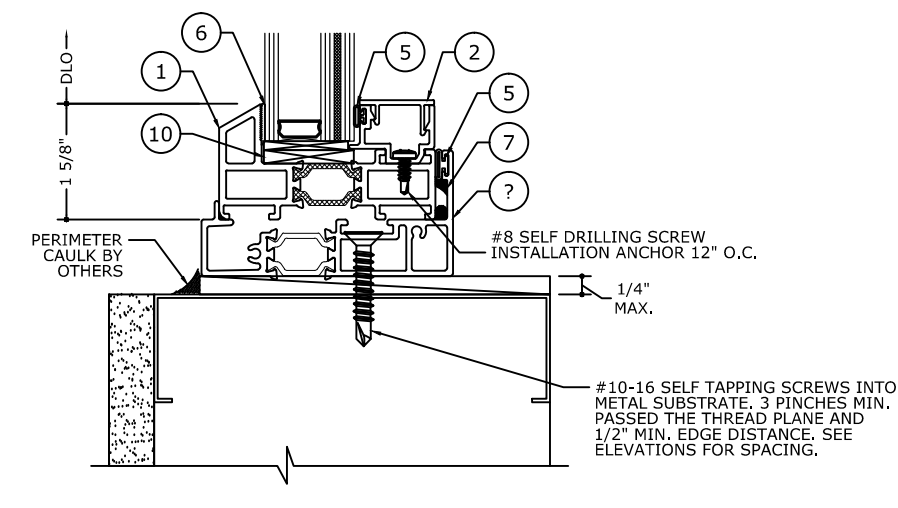

3.5 SILL DETAIL
RECEPTOR

NOTE: REFER TO SYSTEM INSTALLATION MANUAL FOR FABRICATION AND ASSEMBLY INSTRUCTIONS.

FRANK BENNARDO, P.E.
PE# 0046549 CA. 9885

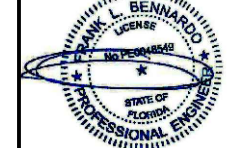

04/19/2021

FL# 38522.1

ENGINEERING EXPRESS
CORPORATE OFFICE:
160 SW 12th AVE, SUITE 106
DEERFIELD BEACH, FL 33442
(954) 354-0660 | (866) 396-9999
TEAM@ENGINEERINGEXPRESS.COM
ENGINEERINGEXPRESS.COM

GRAHAM ARCHITECTURAL PRODUCTS
1551 MT. ROSE AVENUE | YORK, PA 17403
PH: (717) 849-8100
SERIES GT6700 FIXED
FLORIDA STATEWIDE APPROVAL
FLORIDA BUILDING CODE 7TH EDITION (2020)

REMARKS	DRWN	CHKD	DATE
FBC 2020 UPDATE	TAE	AJP	04/01/21

COPYRIGHT ENGINEERING EXPRESS®

21-38803

SCALE: NTS UNLESS NOTED

C:\Users\thayer\appdata\local\temp\AcPublish_11424\21-38803 GT6700 Fixed (2020 FSA).dwg
thayer
04/19/2021 - 6:29pm

VERTICAL JAMB DETAILS

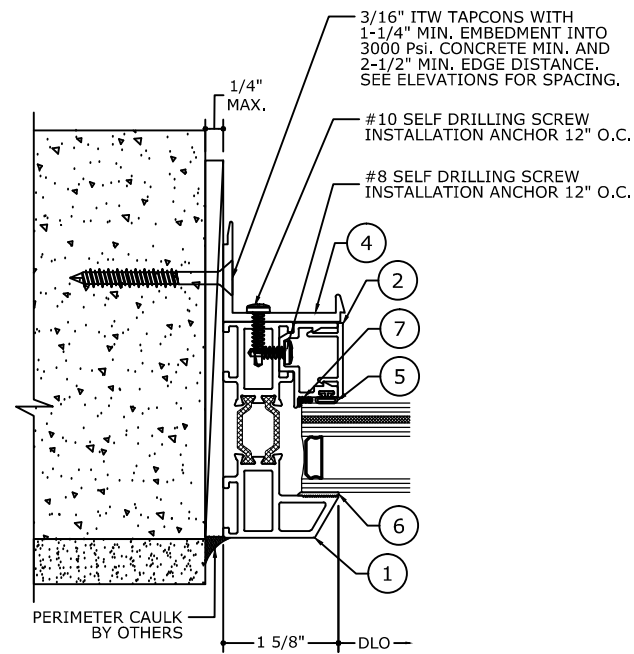

4 JAMB DETAIL
PRE-SET PANNING
SCREW APPLIED BEAD

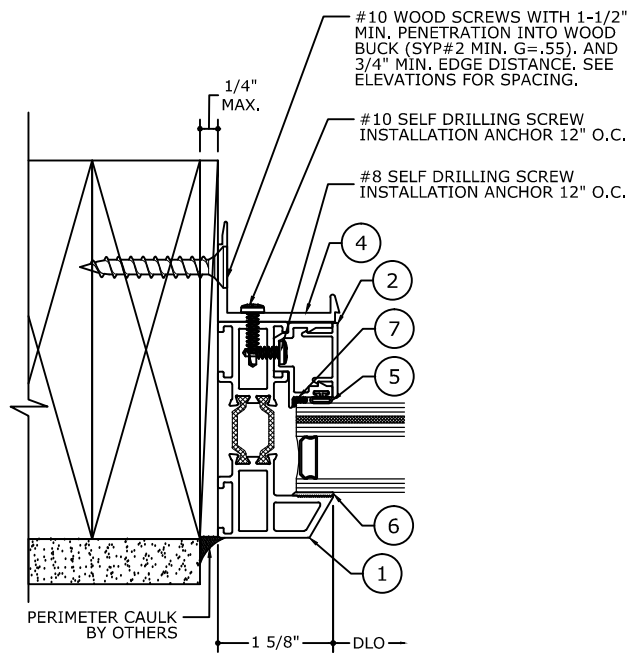

4.1 JAMB DETAIL
PRE-SET PANNING
SCREW APPLIED BEAD

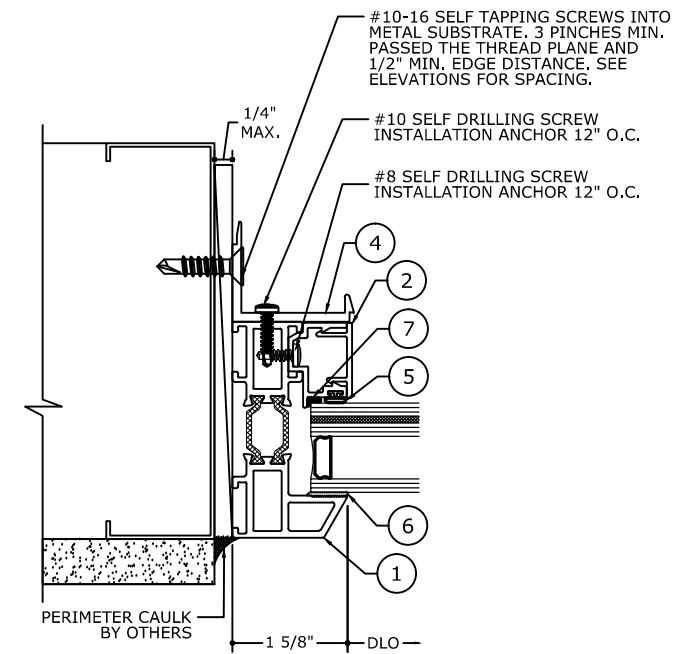

4.2 JAMB DETAIL
PRE-SET PANNING
SCREW APPLIED BEAD

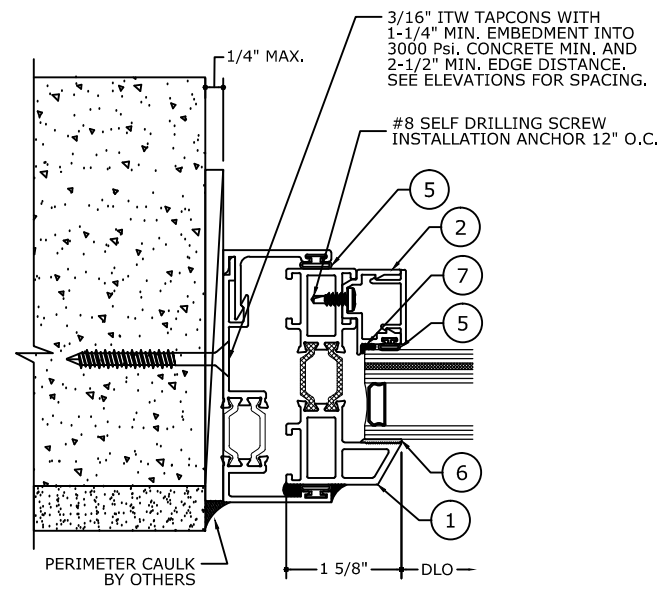

4.3 JAMB DETAIL
RECEPTOR

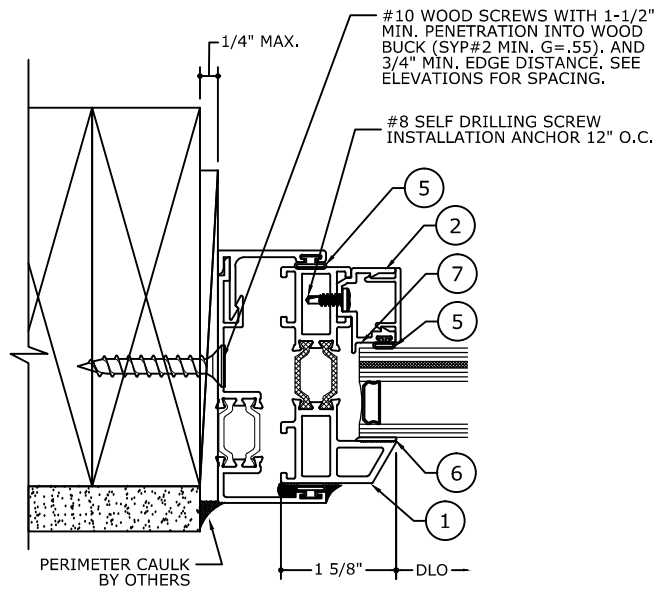

4.4 JAMB DETAIL
RECEPTOR

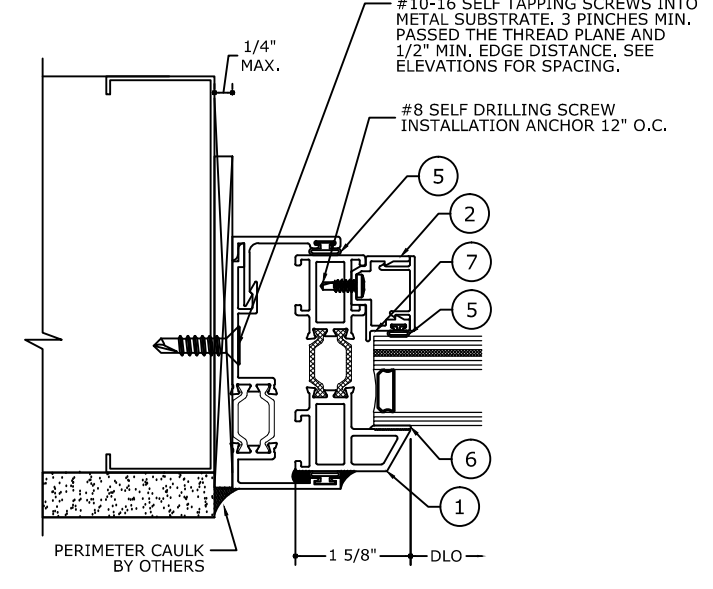

4.5 JAMB DETAIL
RECEPTOR

NOTE: REFER TO SYSTEM INSTALLATION MANUAL FOR FABRICATION AND ASSEMBLY INSTRUCTIONS.

FRANK BENNARDO, P.E.
PE# 0046549 CA. 9885

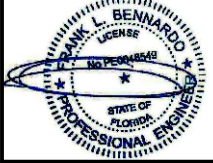

04/19/2021

FL# 38522.1

ENGINEERING EXPRESS
CORPORATE OFFICE:
160 SW 12th AVE, SUITE 106
DEERFIELD BEACH, FL 33442
(954) 354-0660 | (866) 396-9999
TEAM@ENGINEERINGEXPRESS.COM
ENGINEERINGEXPRESS.COM

GRAHAM ARCHITECTURAL PRODUCTS
1551 MT. ROSE AVENUE | YORK, PA 17403
PH: (717) 849-8100

SERIES GT6700 FIXED
FLORIDA STATEWIDE APPROVAL
FLORIDA BUILDING CODE 7TH EDITION (2020)

REMARKS	DRWN	CHKD	DATE
FBC 2020 UPDATE	TAE	AJP	04/01/21

21-38803

SCALE: NTS UNLESS NOTED

C:\Users\thayer\appdata\local\temp\AcPublish_11424\21-38803 GT6700 Fixed (2020 FSA).dwg thayer 04/19/2021 - 6:29pm

SYSTEM COMPONENTS

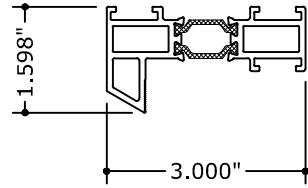

① FIXED FRAME
6063-T5

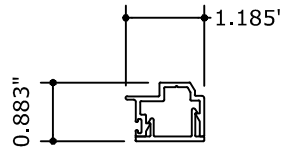

② GLAZING BEAD SCREW APPLIED
6063-T5

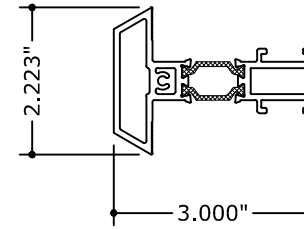

③ NARROW INTERMEDIATE
6063-T5

FRANK BENNARDO, P.E.
PE# 0046549 CA. 9885

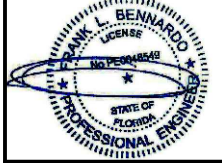

04/19/2021

FL# 38522.1

ENGINEERING EXPRESS®
CORPORATE OFFICE:
160 SW 12th AVE, SUITE 106
DEERFIELD BEACH, FL 33442
(954) 354-0660 | (866) 396-9999
TEAM@ENGINEERINGEXPRESS.COM
ENGINEERINGEXPRESS.COM

GRAHAM ARCHITECTURAL PRODUCTS
1551 MT. ROSE AVENUE | YORK, PA 17403
PH: (717) 849-8100

SERIES GT6700 FIXED
FLORIDA STATEWIDE APPROVAL
FLORIDA BUILDING CODE 7TH EDITION (2020)

REMARKS	DRWN	CHKD	DATE
FBC 2020 UPDATE	TAE	AJP	04/01/21
	-	-	-
	-	-	-
	-	-	-

COPYRIGHT ENGINEERING EXPRESS®

21-38803

SCALE: NTS UNLESS NOTED

BILL OF MATERIALS

ITEM NO.	DESCRIPTION	MATERIAL	MANUFACTURER
1	FIXED - FRAME	ALUM. 6063-T5	
2	GLAZING BEAD w/ COVER	ALUM. 6063-T6	
3	INTERMEDIATE	ALUM. 6063-T5	
4	ALUMINUM CLIP 1/8"	ALUM. 6063-T6	
5	GLAZING BEAD BULB GASKET	5/16 TPE BULB	ULTRAFAB
6	GLAZING COMPOUND	SILICONE	DOWSIL 2400
7	GLAZING COMPOUND	SILICONE	DOWSIL 995
8	3 PIECE MULLION	ALUM. 6063-T5	
9	MULLION - PRESSURE PLATE	ALUM. 6063-T6	
10	GLAZING BLOCK	-	

FRANK BENNARDO, P.E.
PE# 0046549 CA. 9885

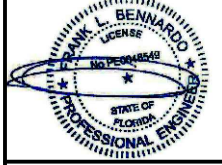

04/19/2021

FL# 38522.1

ENGINEERING EXPRESS®
CORPORATE OFFICE:
160 SW 12th AVE, SUITE 106
DEERFIELD BEACH, FL 33442
(954) 354-0660 | (866) 396-9999
TEAM@ENGINEERINGEXPRESS.COM
ENGINEERINGEXPRESS.COM

GRAHAM ARCHITECTURAL PRODUCTS
1551 MT. ROSE AVENUE | YORK, PA 17403
PH: (717) 849-8100

SERIES GT6700 FIXED
FLORIDA STATEWIDE APPROVAL
FLORIDA BUILDING CODE 7TH EDITION (2020)

REMARKS	DRWN	CHKD	DATE
FBC 2020 UPDATE	TAE	AJP	04/01/21

COPYRIGHT ENGINEERING EXPRESS®

21-38803

SCALE: NTS UNLESS NOTED

16

16