

# Vandal Screen

## SS Mesh

### Full Screen/Optional Spring Latch



Series: 8600 (Formerly: 8600 ) Manufacturing Code: 8602.1000

Drawn  $\frac{1}{2}$  Scale - For Custom Size Drawings Contact Graham

Note: Sealant not shown on details. Consult Technical Services for sealing procedures

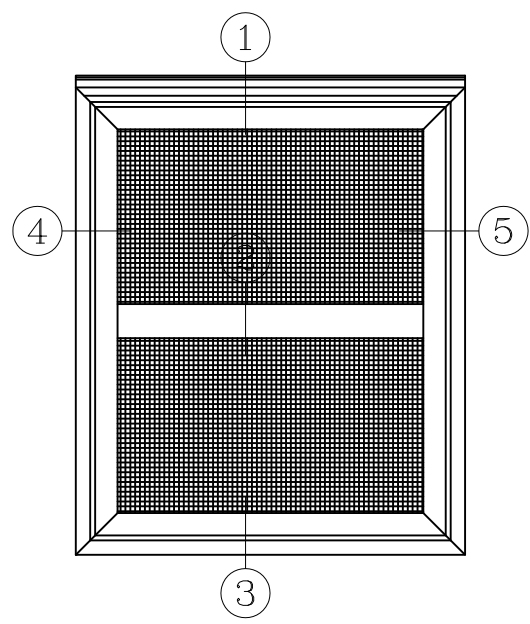
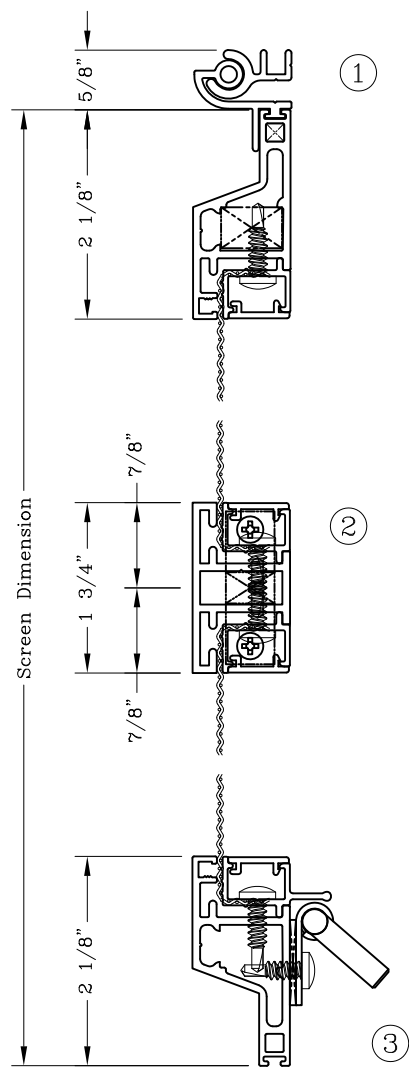

ELEVATION

