

# Hurricane Impact – 3 1/4” Slider



Series: 0300

Manufacturing Code: HI0301

Drawing 1/2 Scale – For Custom Size Drawing Contact Graham

Note: Sealant Not Shown On Details. Consult Technical Services At Factory For Sealing Procedures.

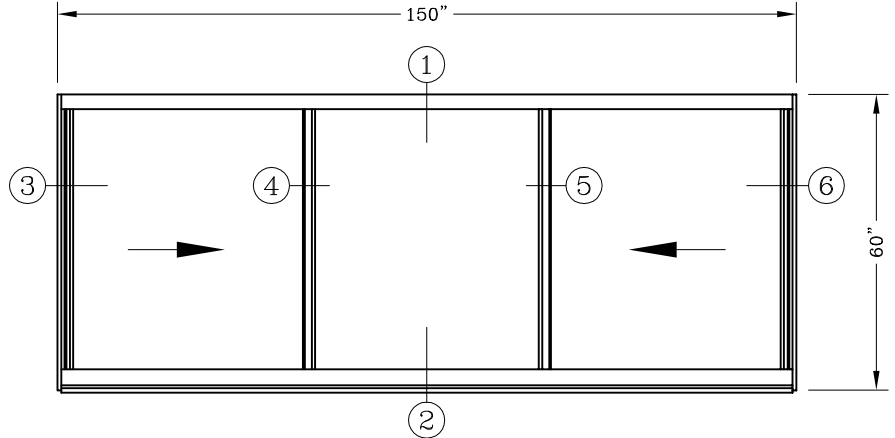
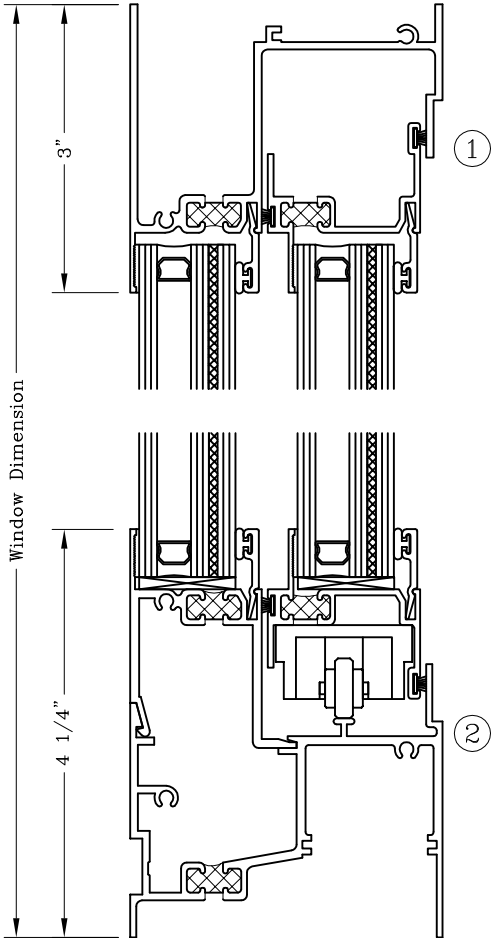

ELEVATION  
XOX – Shown

### INSTALLATION TYPES

1. Trim And Clip

(Reference Test Report #f7490.01-109-44)

Glazing To Be:  
1" IG Consisting Of;  
3/16" Annealed Exterior,  
And 7/16" Lami  
Consisting of;  
(3/16" Thick Annealed Exterior,  
.090 PVB Interlayer (Saflex),  
3/16" Thick Annealed Interior)

