

# ARCHITECTURAL SUNSHADES ELEVATIONS

Series:



**Drawing No Scale – For Custom Size Drawing Contact Graham**

Note: Consult Technical Services At Factory For Sealing Procedures.

## *Architectural Sunshades*

*Standard Details, No Scale*

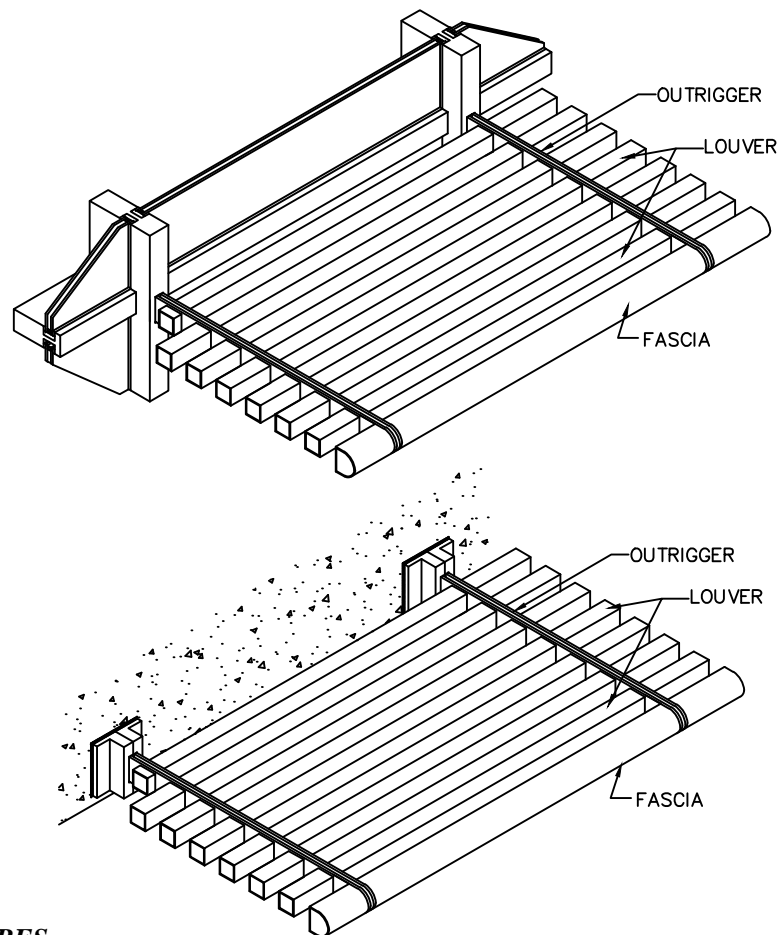

### **FEATURES:**

- *All aluminum design reduces maintenance and weight*
- *Units are assembled using screw spline connections with stainless steel fasteners*
- *Can be integrated with F-M 2500 series pressure wall*
- *Can be wall mounted above existing windows*
- *Available with standard or custom profiles*
- *Shades interior and conserves energy*
- *Standard 34" projection from face of glass*
- *Anchorage designed to accommodate a combined 65 psf wind and snow load.*

# ARCHITECTURAL SUNSHADES DETAILS

Series:



Drawing No Scale - For Custom Size Drawing Contact Graham

Note: Consult Technical Services At Factory For Sealing Procedures.

## *Architectural Sunshades* *Vertical and Horizontal Sunshades* *attached to structurally glazed Curtainwall*

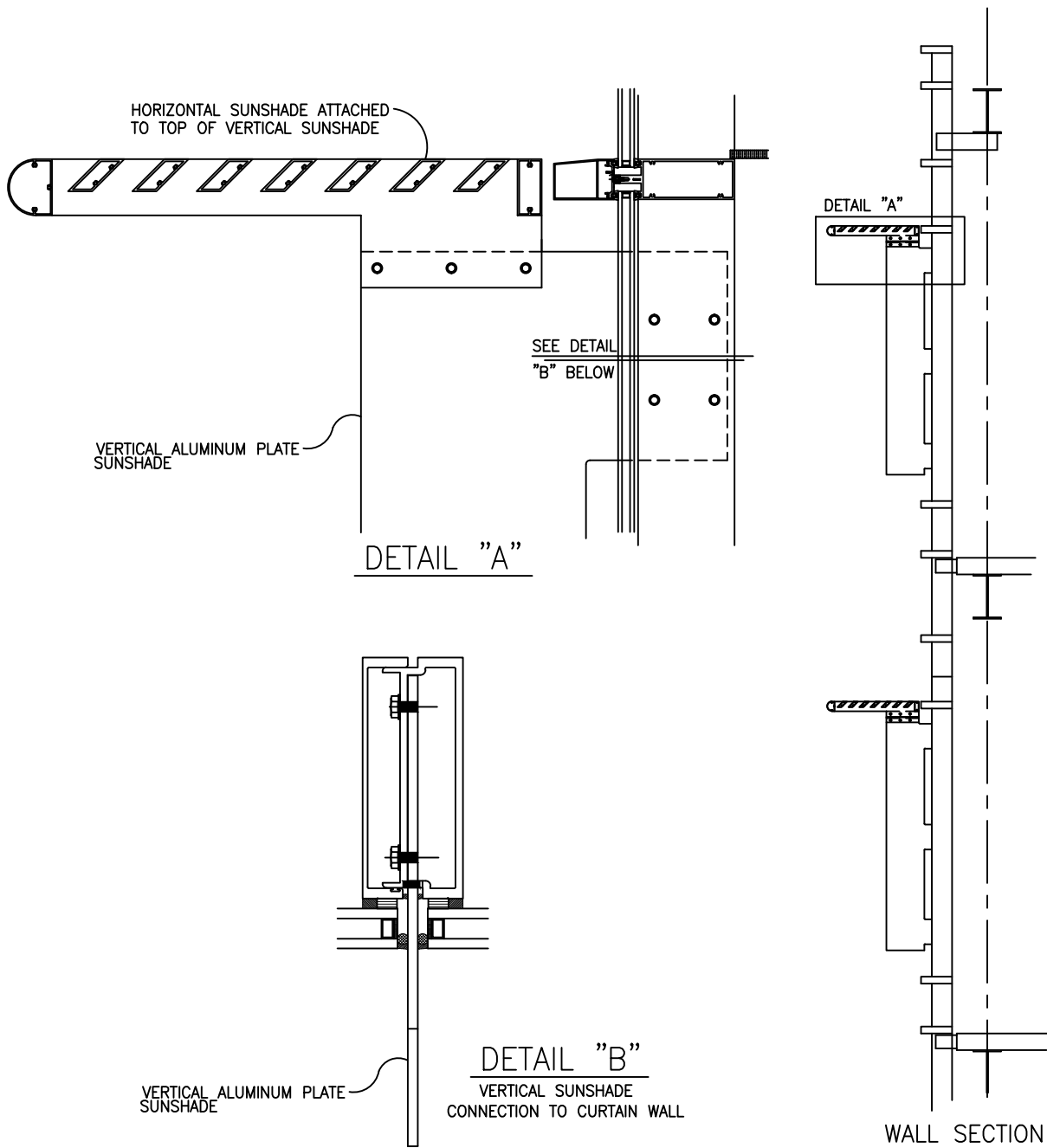

# ARCHITECTURAL SUNSHADES 2500 SERIES WALL

Series:



**Drawing No Scale – For Custom Size Drawing Contact Graham**

Note: Consult Technical Services At Factory For Sealing Procedures.

## Architectural Sunshades Attached to F-M 2500 Series Wall

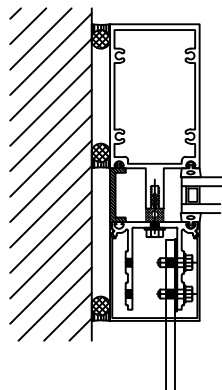
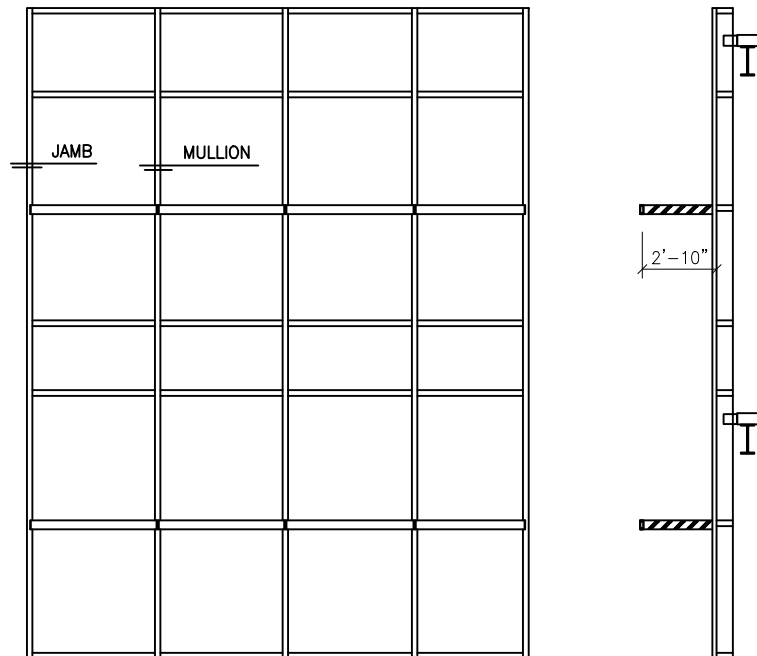

SUNSHADE AT JAMB

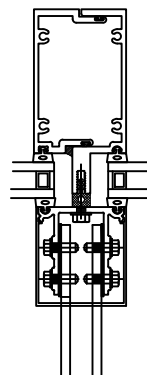

SUNSHADE AT MULLION

# ARCHITECTURAL SUNSHADES 2500 SERIES WALL

Series:



Drawing No Scale – For Custom Size Drawing Contact Graham

Note: Consult Technical Services At Factory For Sealing Procedures.

## *Architectural Sunshades* *Wall Mounted Option*

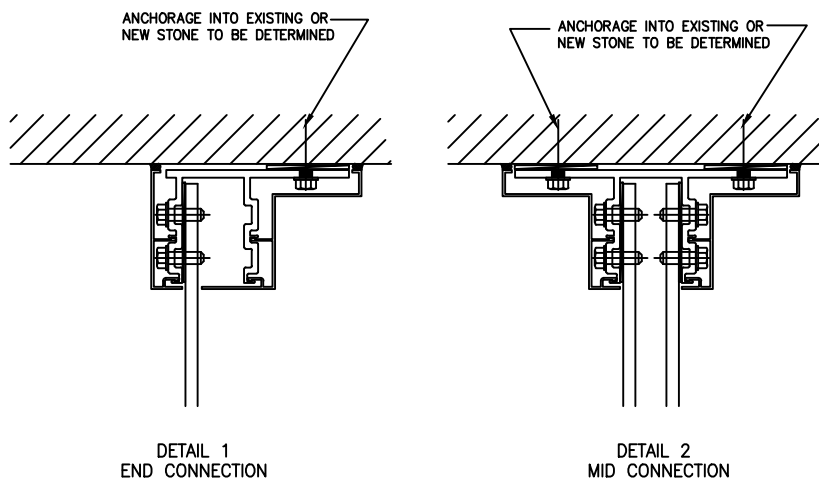
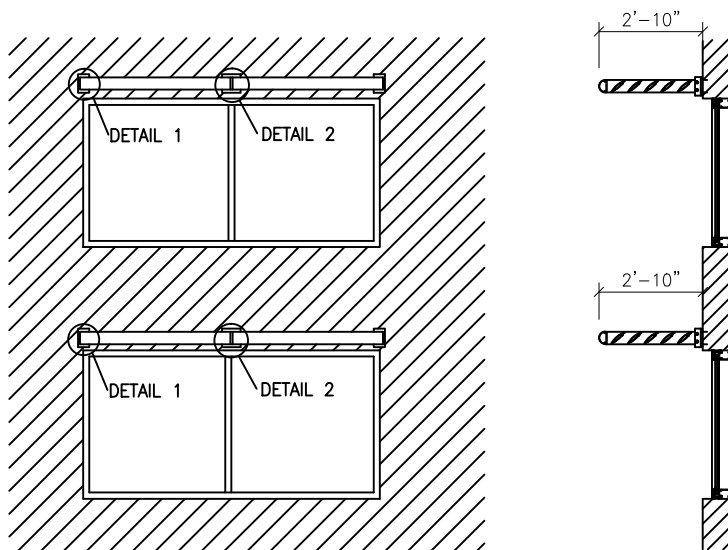

# ARCHITECTURAL SUNSHADES



Series:

Drawing No Scale – For Custom Size Drawing Contact Graham

Note: Consult Technical Services At Factory For Sealing Procedures.

## Architectural Sunshades

**NARROW STILE OUTRIGGER**  
SHOWN ATTACHED TO CURTAIN WALL VERTICAL

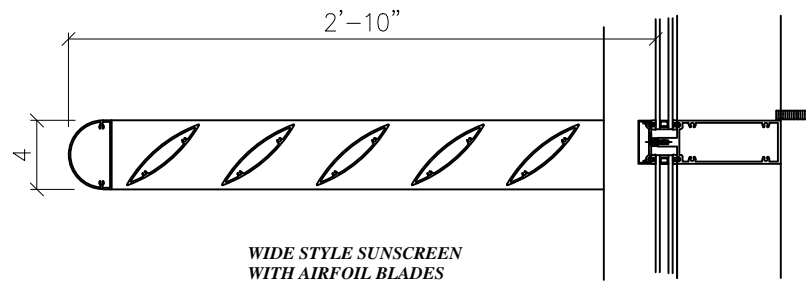

WIDE STYLE SUNSCREEN  
WITH AIRFOIL BLADES

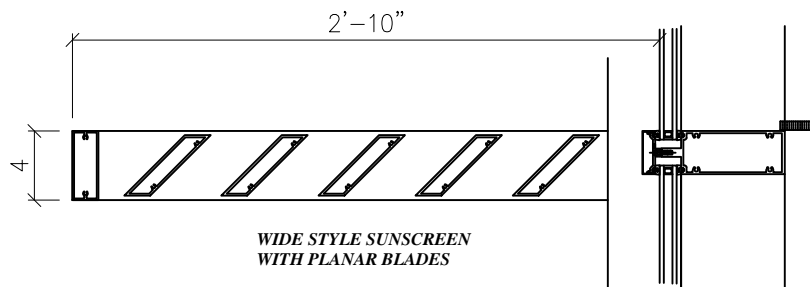

WIDE STYLE SUNSCREEN  
WITH PLANAR BLADES

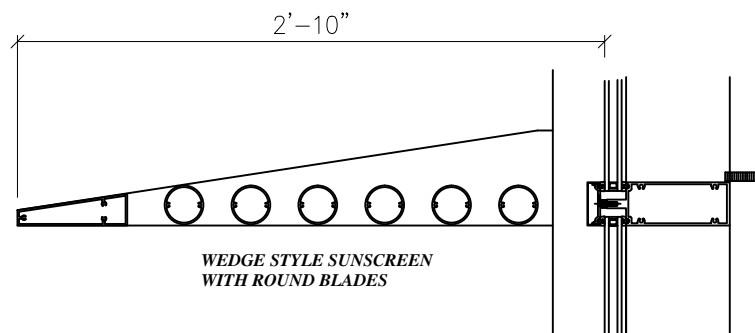

WEDGE STYLE SUNSCREEN  
WITH ROUND BLADES

# ARCHITECTURAL SUNSHADES



Series:

Drawing No Scale - For Custom Size Drawing Contact Graham

Note: Consult Technical Services At Factory For Sealing Procedures.

## Architectural Sunshades

NARROW STILE OUTRIGGER  
SHOWN ATTACHED TO CURTAIN WALL VERTICAL

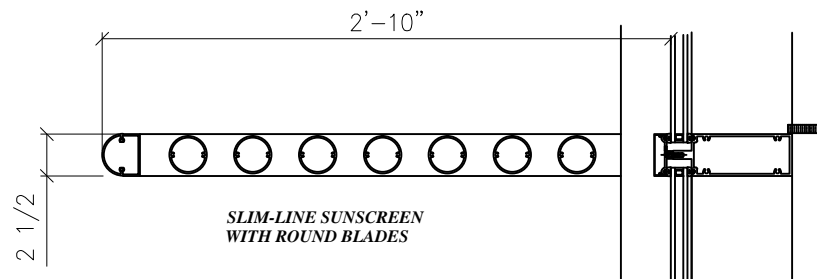
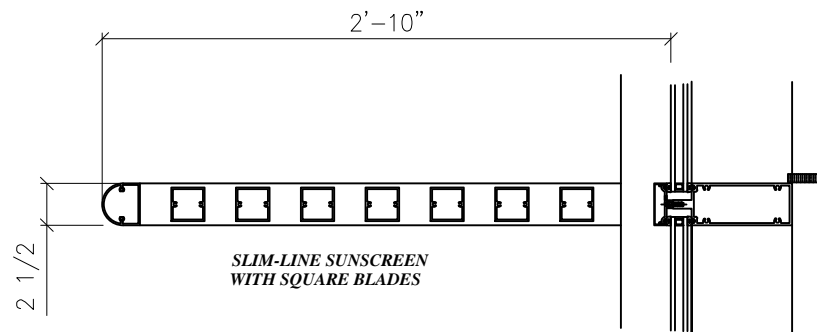
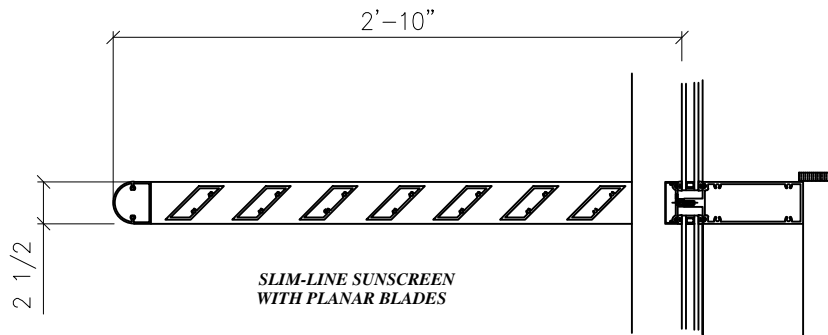

# ARCHITECTURAL SUNSHADES



Series:

Drawing No Scale – For Custom Size Drawing Contact Graham

Note: Consult Technical Services At Factory For Sealing Procedures.

## Architectural Sunshades Standard Blade Profiles, No Scale

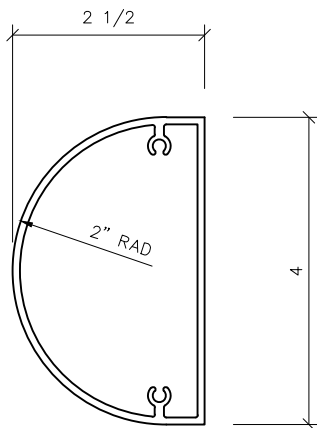

**4" WIDE ROUND**

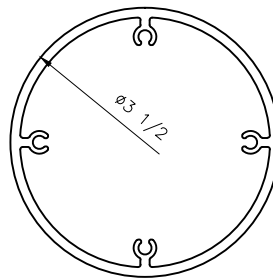

**3 1/2" ROUND**

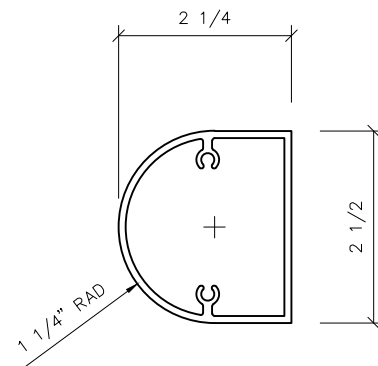

**2 1/2" WIDE ROUND**

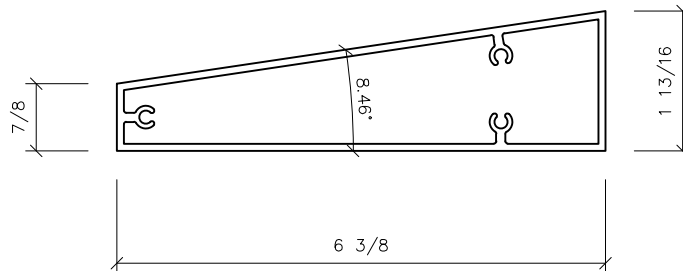
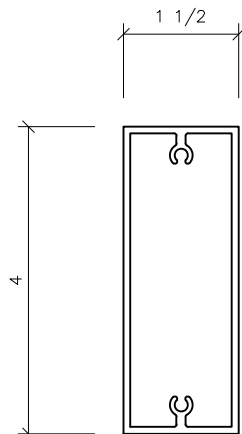

**WEDGE**

# ARCHITECTURAL SUNSHADES



Series:

Drawing No Scale – For Custom Size Drawing Contact Graham

Note: Consult Technical Services At Factory For Sealing Procedures.

## Architectural Sunshades Standard Blade Profiles, No Scale

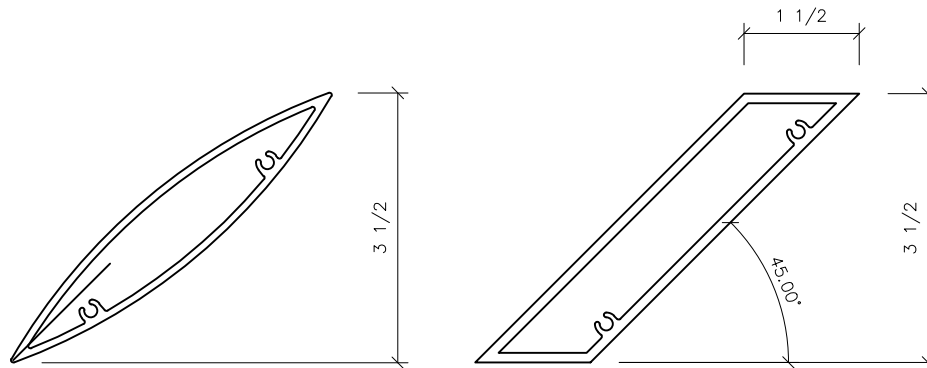

3 1/2" AIRFOIL

1 1/2"x3 1/2" PLANER

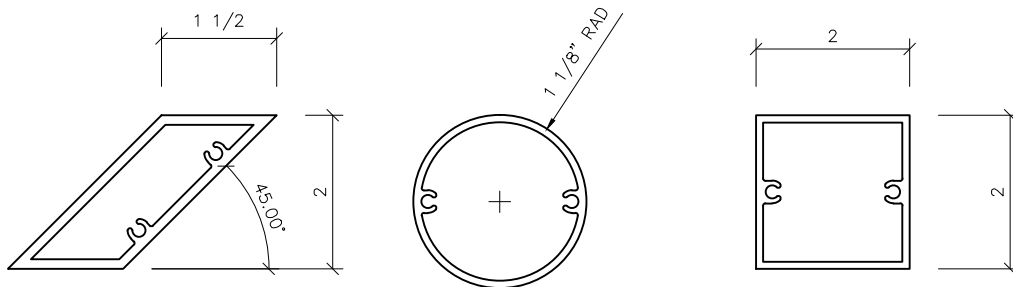

1 1/2"x2" PLANER

2 1/4" DIAMETER

2" SQUARE

