

# Accessories – 3 1/4” Products



Series: Accessories Manufacturing Code: AC03B

Drawing 1/2 Scale – For Custom Size Drawing Contact Graham

Note: Sealant Not Shown On Details. Refer To General Installation Instructions.

Note: Not All Options Are Shown, Contact Graham For Other Options.

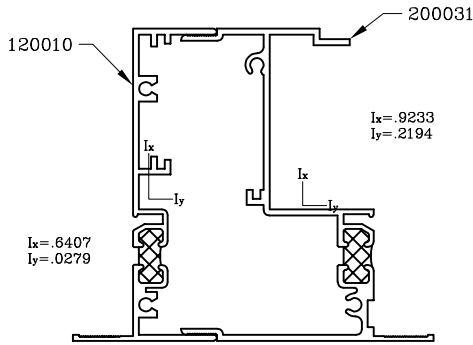

1200 Series With 2000 Series

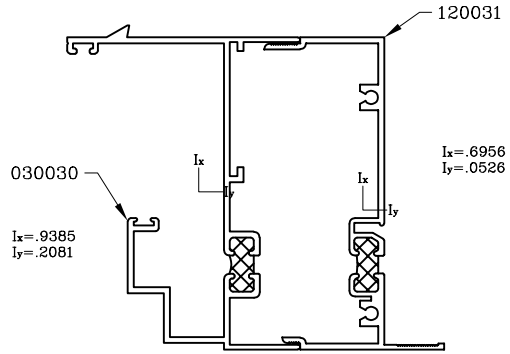

0300 Series With 1200 Series

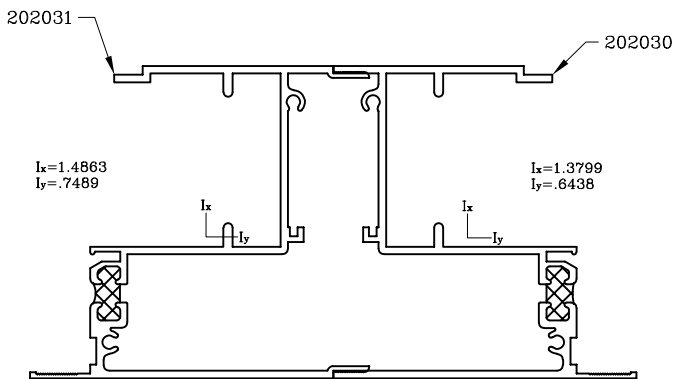

2000 Series With 2000 Series

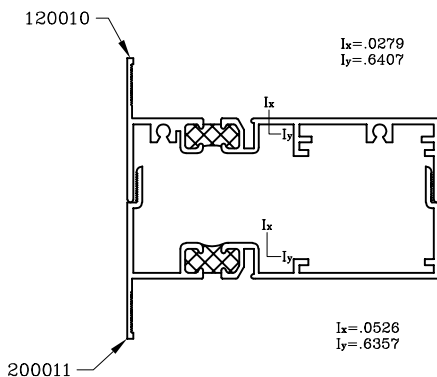

1200 Series With 2000 Series

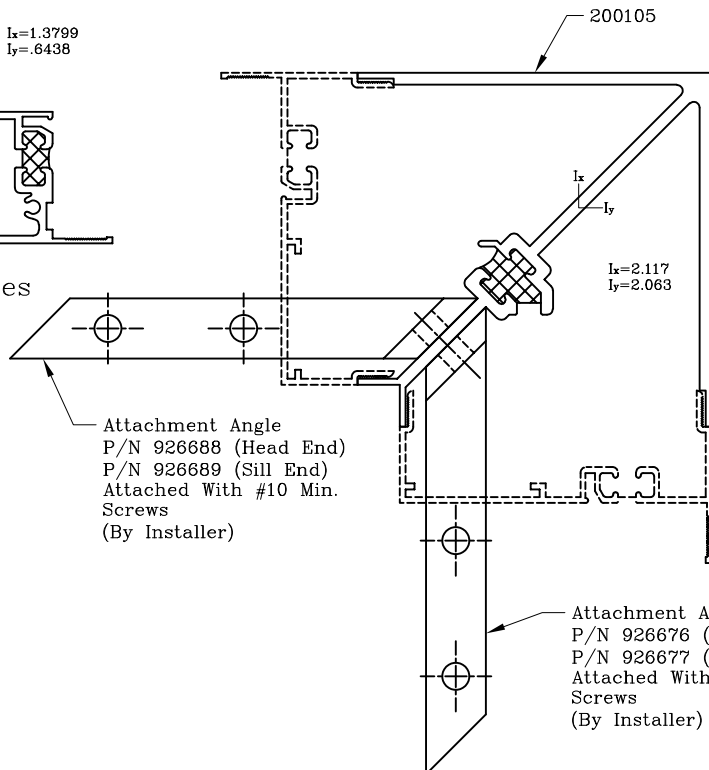

90° Corner Mullion

Graham Architectural Products reserves the right to change, add, cancel, remove or otherwise modify the details illustrated without prior notice.

1551 Mt. Rose Avenue, York, Pennsylvania 17403-2909 717.849.8100 Toll Free: 800/755-6274

0223 – AC.03B

Web Site: [www.grahamwindows.com](http://www.grahamwindows.com)