

# Accessories - 3 1/4" Products



Series: Accessories Manufacturing Code: AC03F

Drawing 1/2 Scale - For Custom Size Drawing Contact Graham

Note: Sealant Not Shown On Details. Refer To General Installation Instructions.

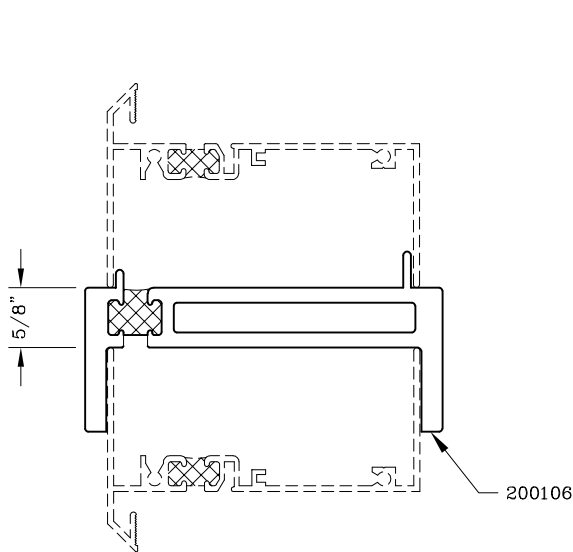

Stack Mull - Heavy Wall

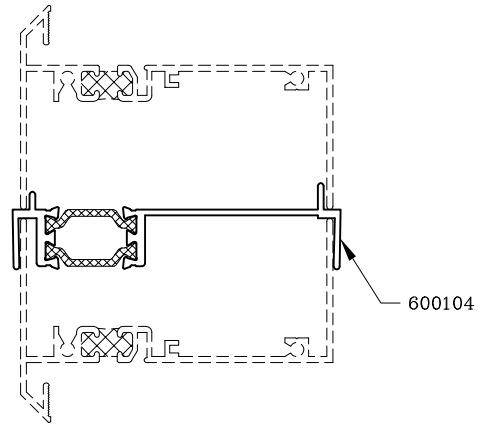

Stack Mull - Struttet

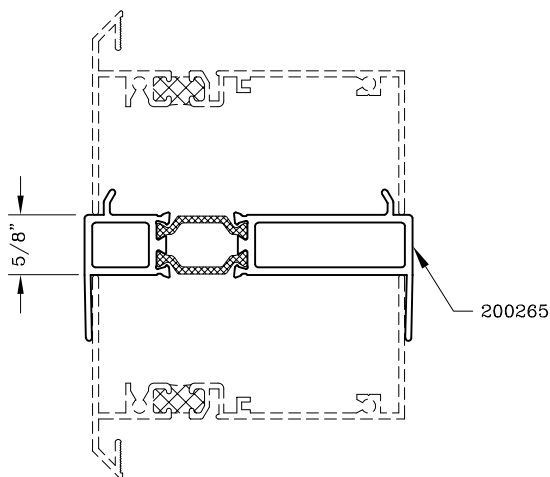

Stack Mull - Struttet

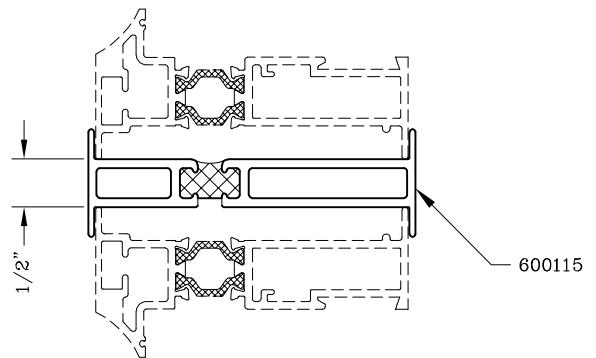

Stack Mull - SR6700

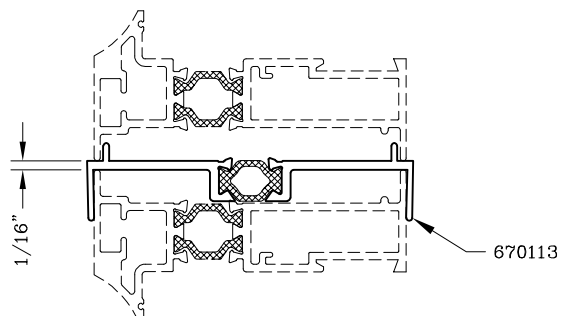

Stack Mull - SR6700

Graham Architectural Products reserves the right to change, add, cancel, remove or otherwise modify the details illustrated without prior notice.

1551 Mt. Rose Avenue, York, Pennsylvania 17403-2909 717.849.8100 Toll Free: 800/755-6274

0223 - AC.03F

Web Site: [www.grahamwindows.com](http://www.grahamwindows.com)