

Accessories - 3 1/4" Products



Series: Accessories Manufacturing Code: AC03K

Drawing 1/2 Scale - For Custom Size Drawing Contact Graham

Note: Sealant Not Shown On Details. Refer To General Installation Instructions.

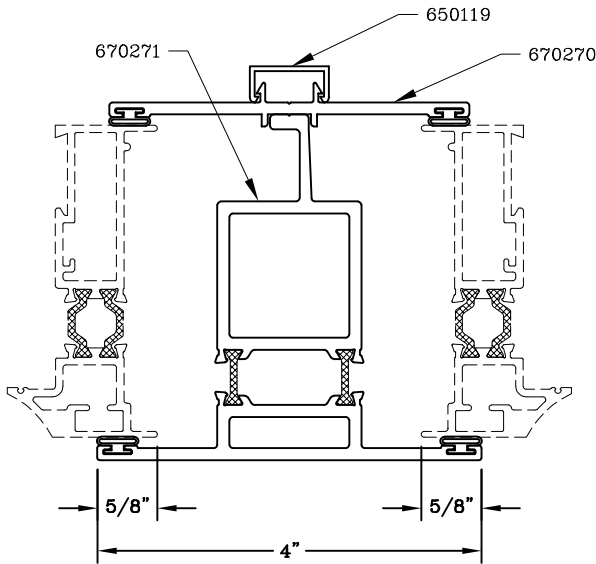

Vertical Mullion - 4" Face

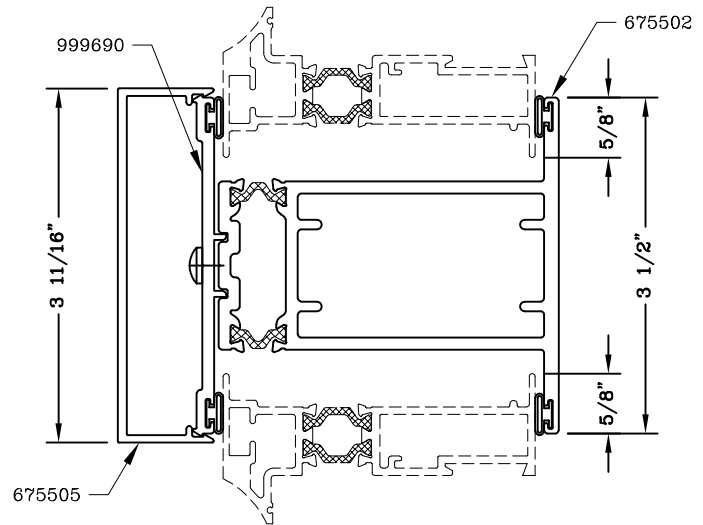

Horizontal Mullion

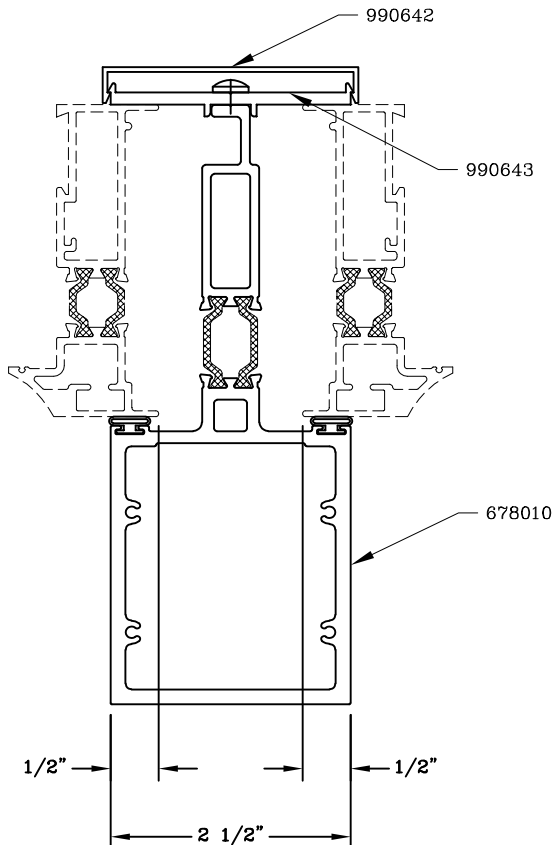

Vertical Tube Mullion - 2 1/2" Face

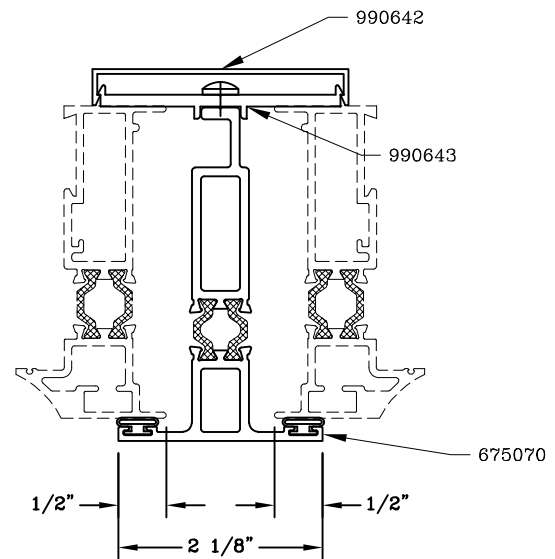

Vertical Mullion - 2 1/8" Face

Graham Architectural Products reserves the right to change, add, cancel, remove or otherwise modify the details illustrated without prior notice.

1551 Mt. Rose Avenue, York, Pennsylvania 17403-2909 717.849.8100 Toll Free: 800/755-6274

0223 - AC.03K

Web Site: www.grahamwindows.com