

# Accessories – 4 1/2" Product



Series: Accessories Manufacturing Code: AC06E

Drawing 1/2 Scale – For Custom Size Drawing Contact Graham

Note: Sealant Not Shown On Details. Refer To General Installation Instructions.

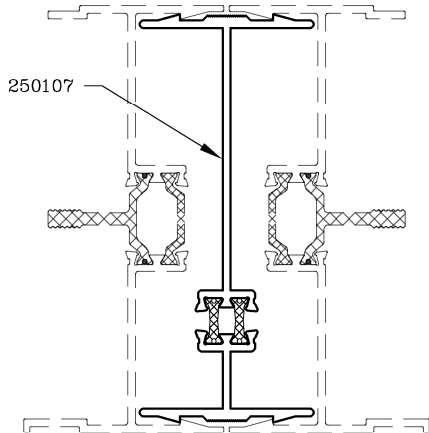

Zero Mullion

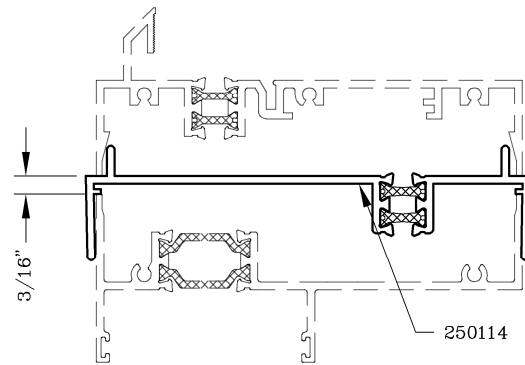

Stack Mullion

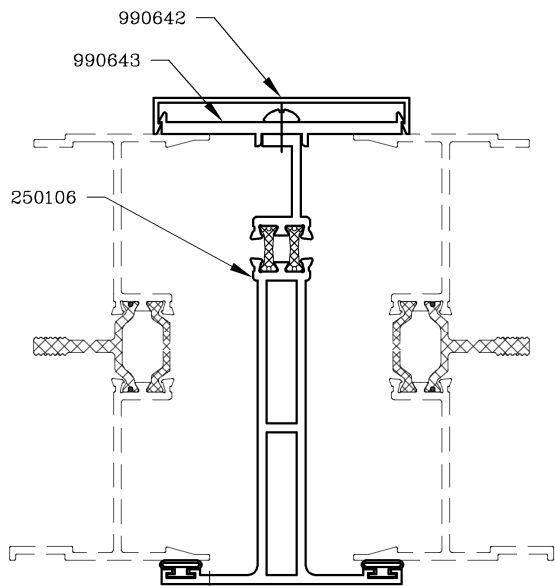

3 Piece Mullion

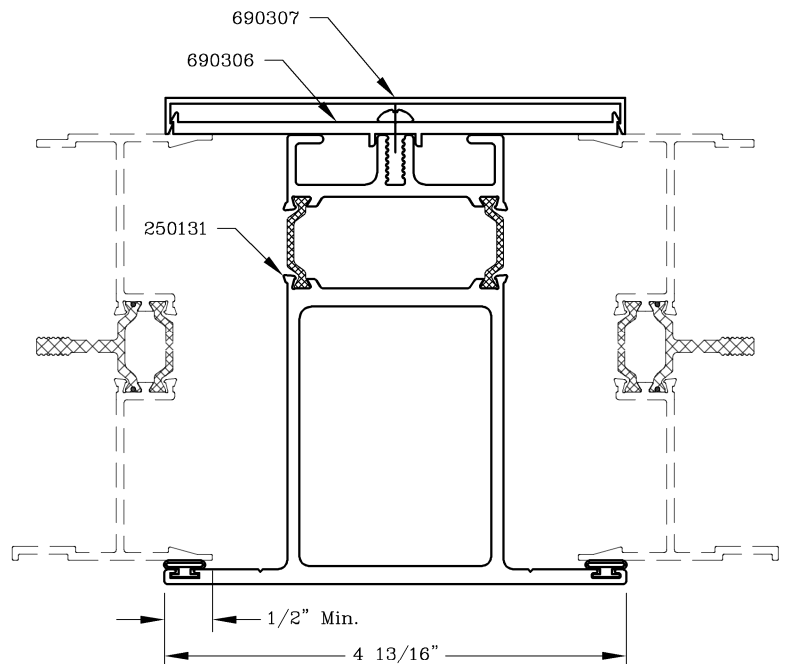

3 Piece Mullion

Graham Architectural Products reserves the right to change, add, cancel, remove or otherwise modify the details illustrated without prior notice.

1551 Mt. Rose Avenue, York, Pennsylvania 17403-2909 717.849.8100 Toll Free: 800/755-6274

Web Site: [www.grahamwindows.com](http://www.grahamwindows.com)

0124 – AC.06E

# Accessories – 4 1/2" Product



Series: Accessories Manufacturing Code: AC06F

Drawing 1/2 Scale – For Custom Size Drawing Contact Graham

Note: Sealant Not Shown On Details. Refer To General Installation Instructions.

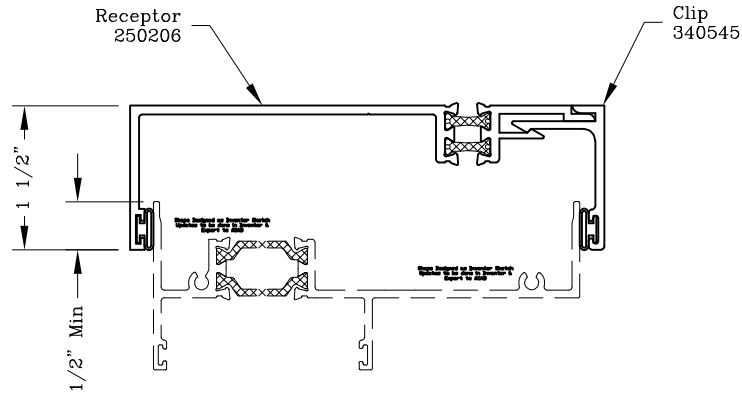

Head/Jamb Receptor

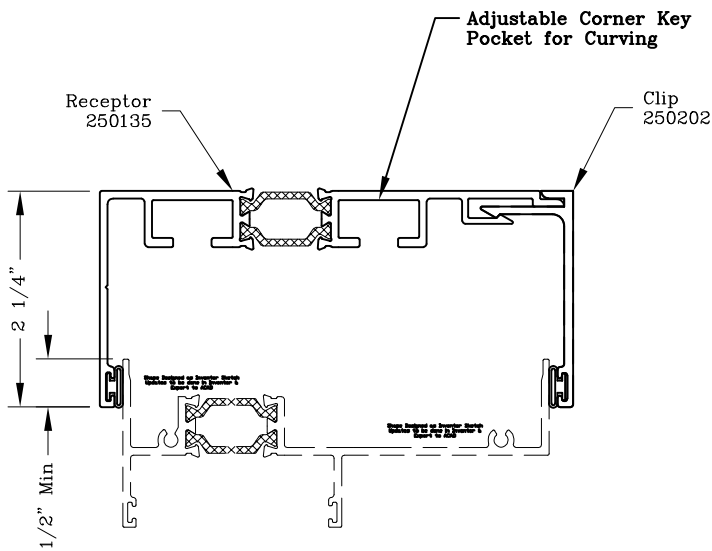

Head/Jamb Receptor

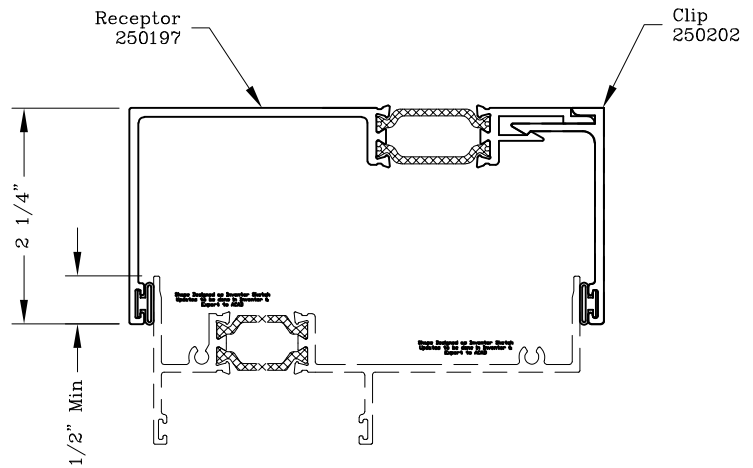

Head/Jamb Receptor

# Accessories - 4 1/2" Product



Series: Accessories Manufacturing Code: AC06G

Drawing 1/2 Scale - For Custom Size Drawing Contact Graham

Note: Sealant Not Shown On Details. Refer To General Installation Instructions.

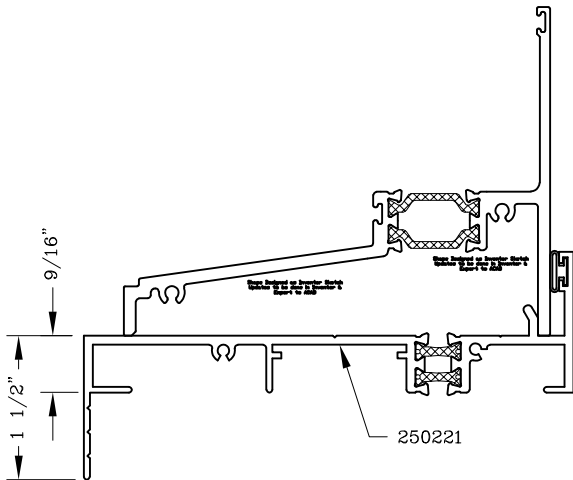

Sill Starter

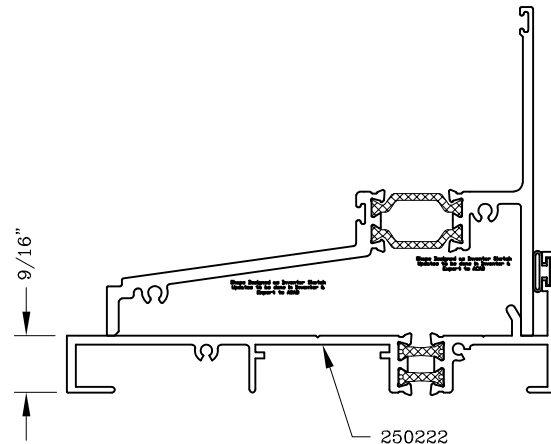

Sill Starter

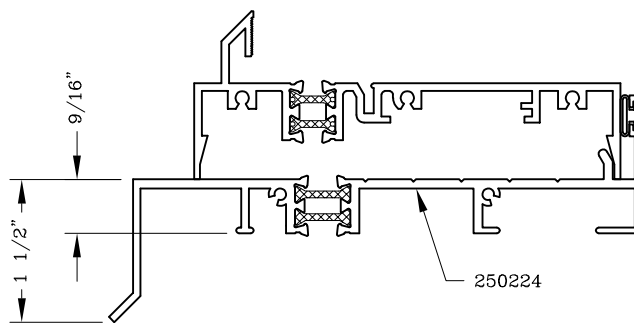

Sill Starter