

Accessories – GT Products 3 1/4"



Series: Accessories Manufacturing Code: GT03A

Drawing 1/2 Scale – For Custom Size Drawing Contact Graham

Note: Sealant Not Shown On Details. Refer To General Installation Instructions.

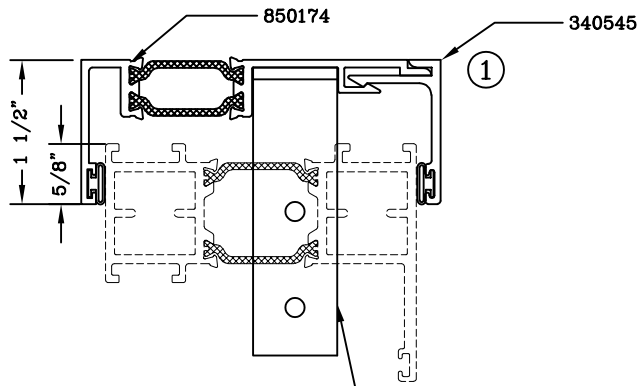

Attachment Angle for 3 pc Mullion P/N 929308
Attach with #10 M.N. Screws (By Installer)

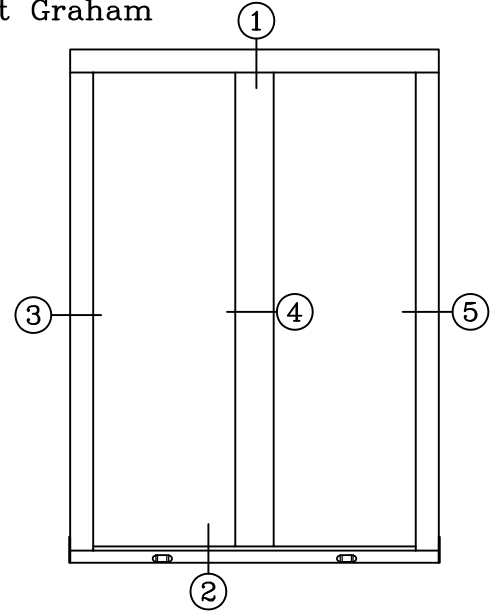

ELEVATION

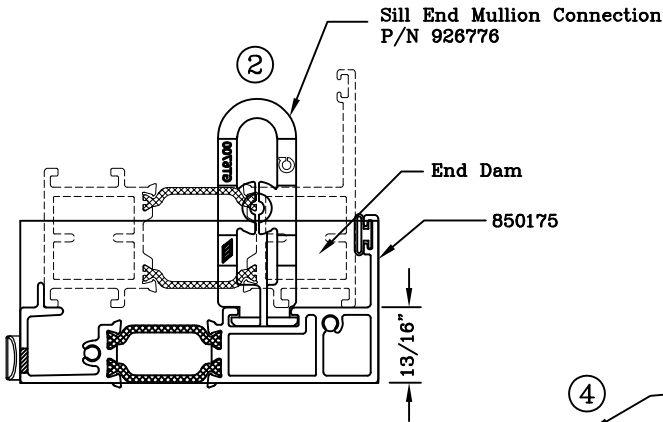

Sill End Mullion Connection
P/N 926776

End Dam

850178

End Dam

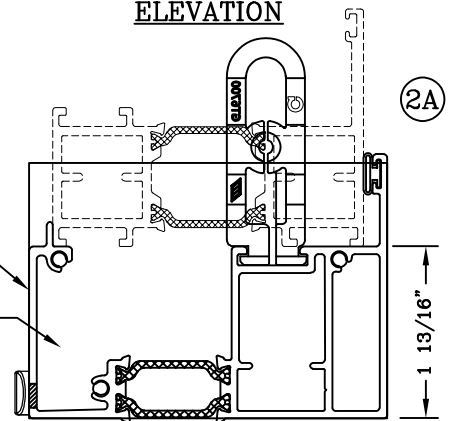

2A

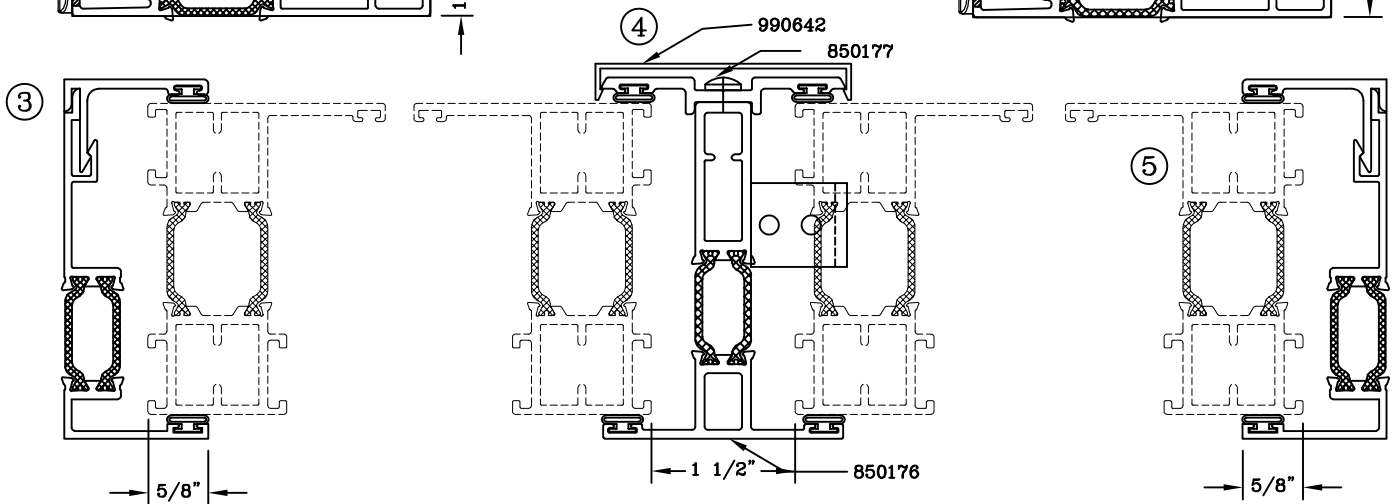

Graham Architectural Products reserves the right to change, add, cancel, remove or otherwise modify the details illustrated without prior notice.

1551 Mt. Rose Avenue, York, Pennsylvania 17403-2909 717.849.8100 Toll Free: 800/755-6274 0223 – AC.GT03A

Web Site: www.grahamwindows.com