

Single Hung Side Load - 4" GMAC Hardware



Series: GT2200 Manufacturing Code: GT2222

Drawing 1/2 Scale - For Custom Size Drawing Contact Graham

Note: Sealant Not Shown On Details. Refer To General Installation Instructions.

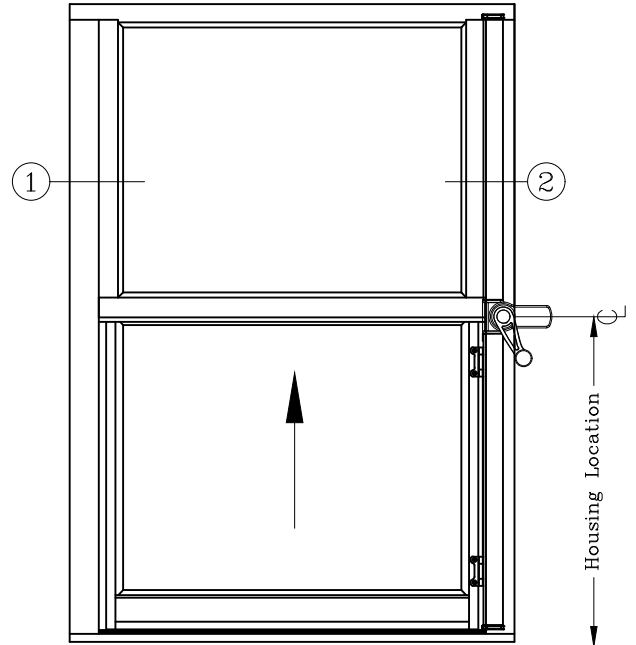
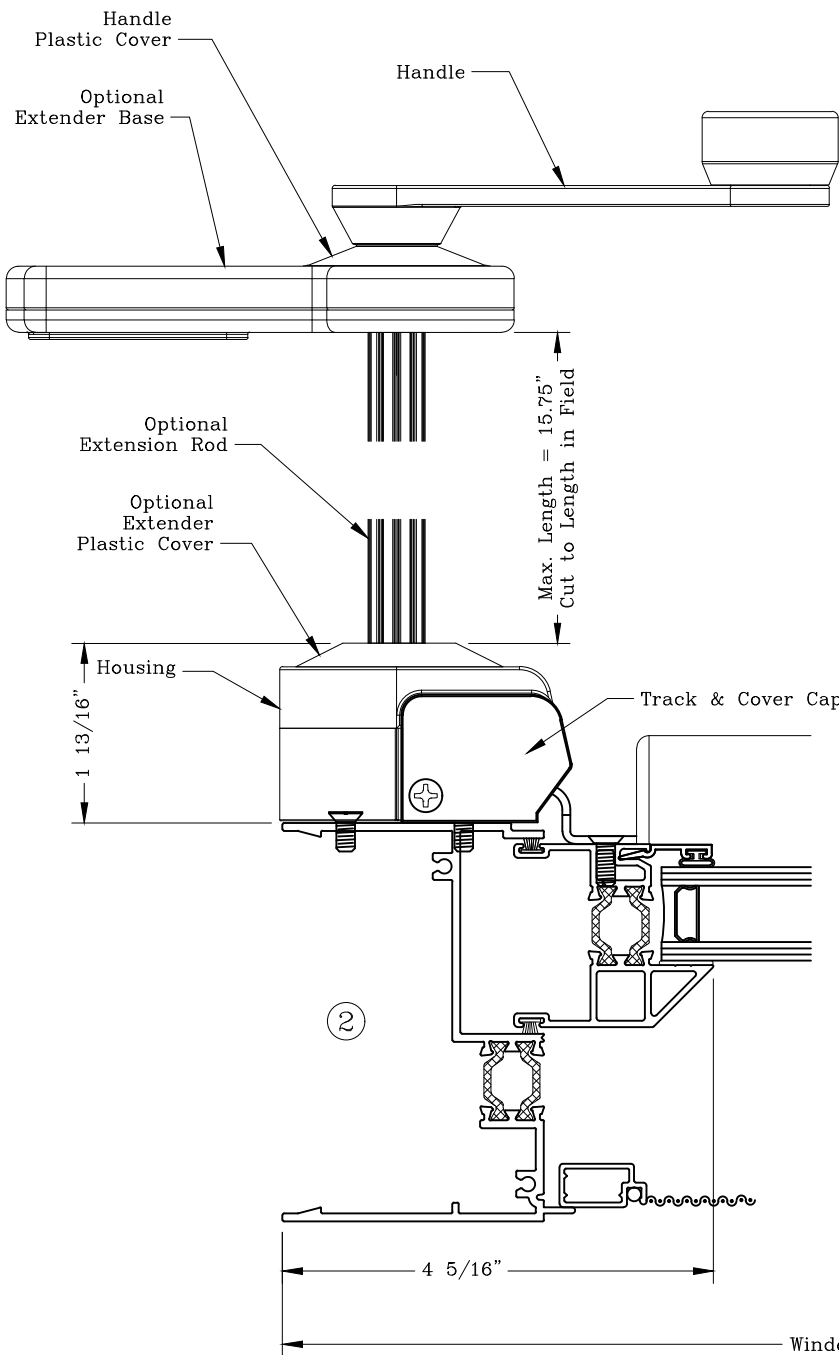

Elevation
Viewed From The Interior

Note:
For vertical cross section details reference sheet GT22_20

