

Fixed Offset - 4" 1" IG



Series: S1400H Manufacturing Code: S1408

Drawing 1/2 Scale - For Custom Size Drawing Contact Graham

Note: Sealant Not Shown On Details. Refer To General Installation Instructions.

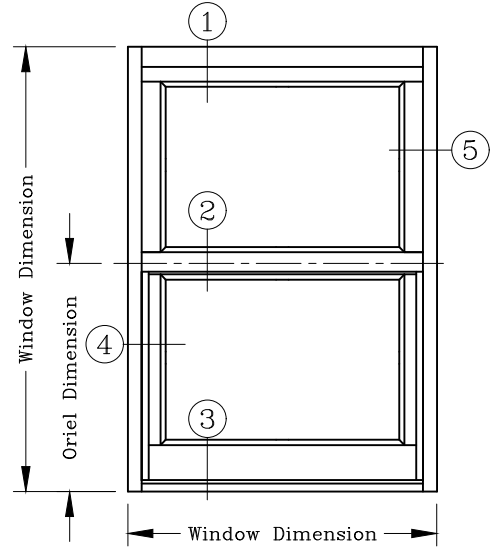
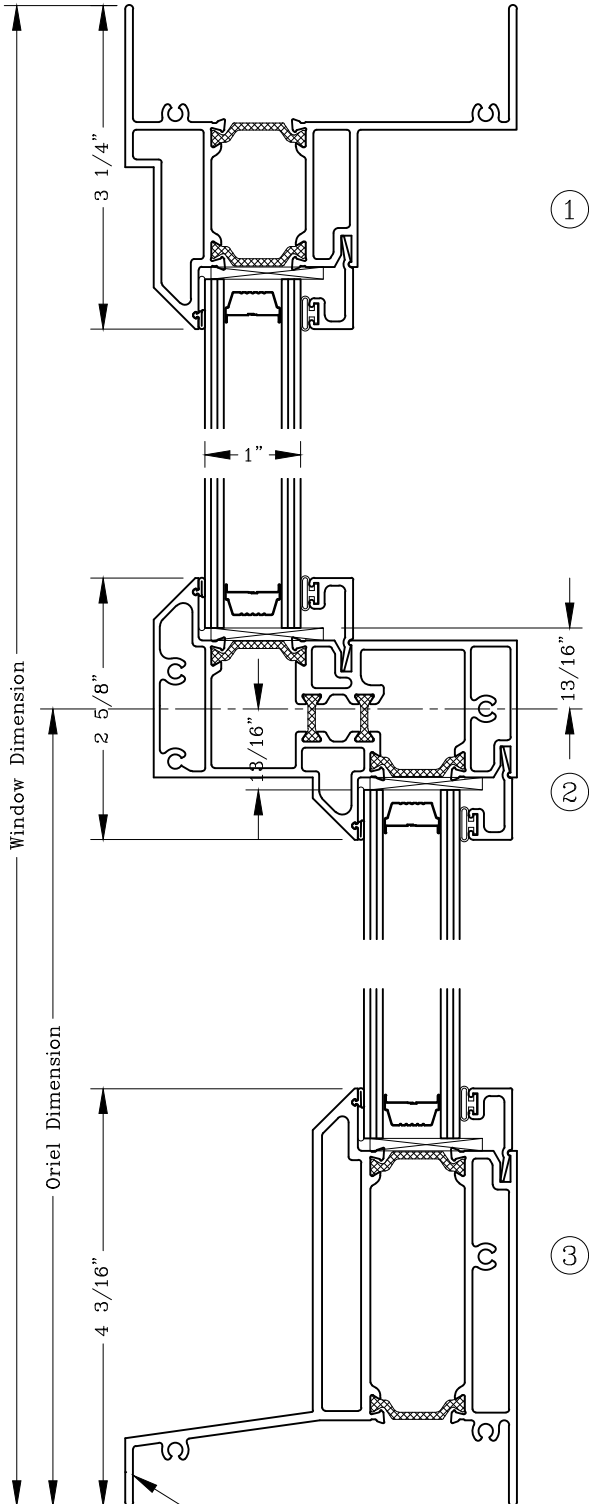

ELEVATION

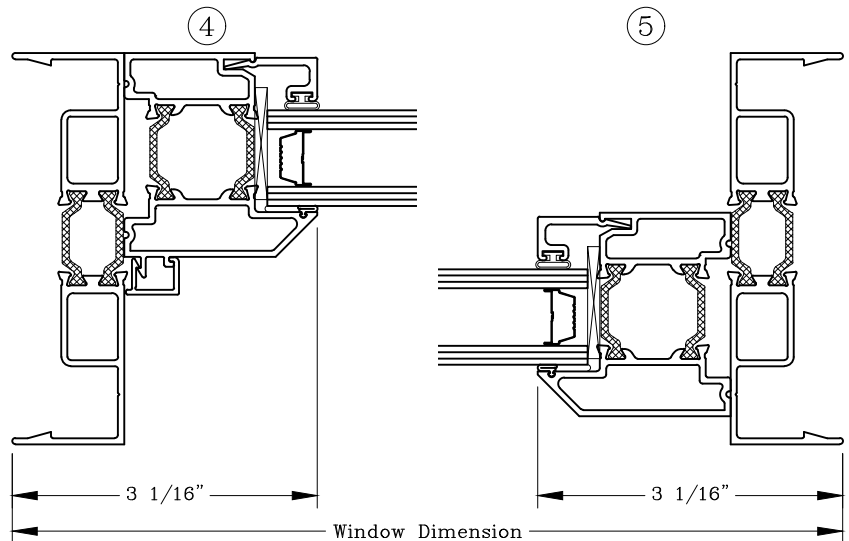

Equal Leg Shown
Panning Leg Sill Available For Attached
Panning Applications

Graham Architectural Products reserves the right to change, add, cancel, remove or otherwise modify the details illustrated without prior notice.

1551 Mt. Rose Avenue, York, Pennsylvania 17403-2909 717.849.8100 Toll Free: 800/755-6274

0723 - S14.08

Web Site: www.grahamwindows.com

Fixed Offset - 4"

1 1/4" IG



Series: S1400H Manufacturing Code: S1410

Drawing 1/2 Scale - For Custom Size Drawing Contact Graham

Note: Sealant Not Shown On Details. Refer To General Installation Instructions.

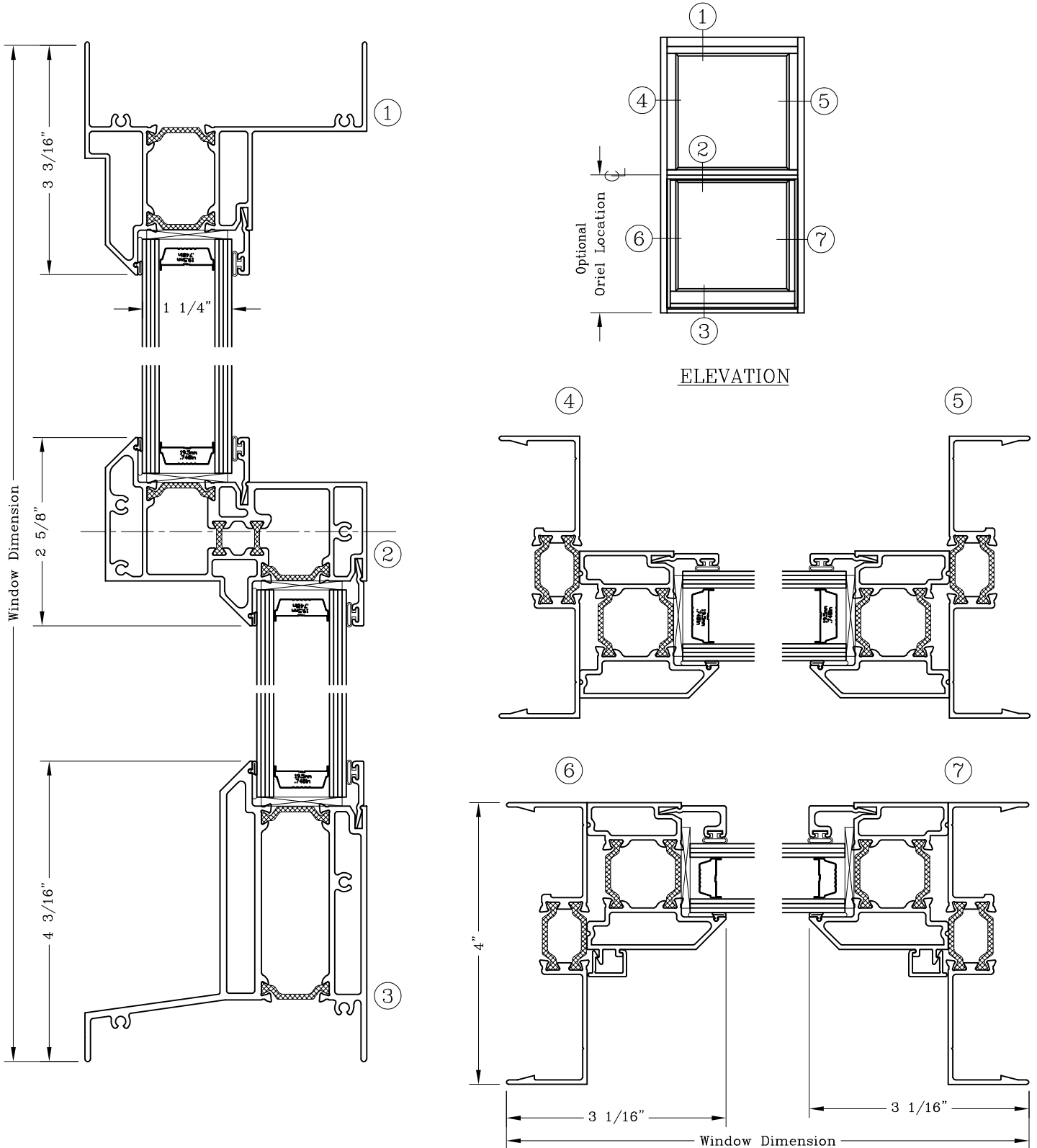

Graham Architectural Products reserves the right to change, add, cancel, remove or otherwise modify the details illustrated without prior notice.

1551 Mt. Rose Avenue, York, Pennsylvania 17403-2909 717.849.8100 Toll Free: 800/755-6274

0823 - S14.10

Web Site: www.grahamwindows.com

Fixed Offset - 4"
 1 1/4" IG
 Single Plane



Series: S1400H

Manufacturing Code: S1411

Drawing 1/2 Scale - For Custom Size Drawing Contact Graham

Note: Sealant Not Shown On Details. Refer To General Installation Instructions.

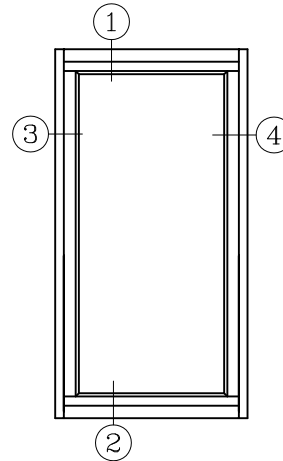
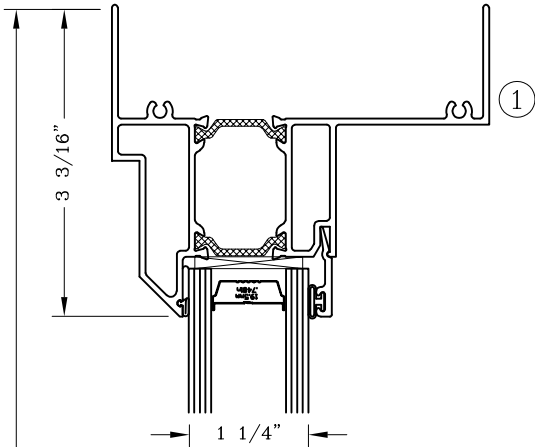

ELEVATION

Window Dimension

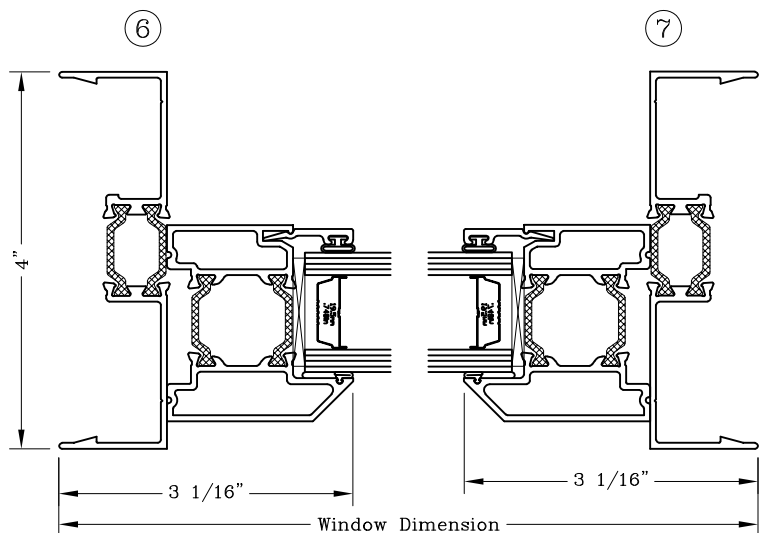
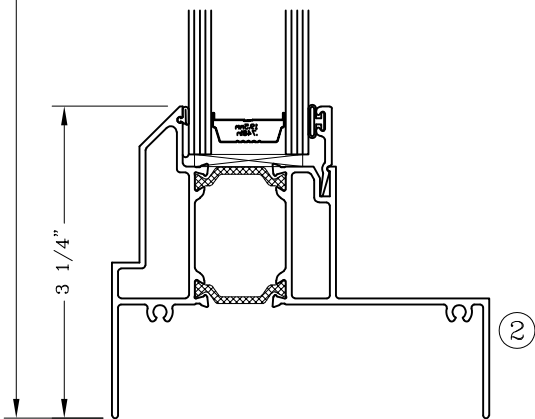

Graham Architectural Products reserves the right to change, add, cancel, remove or otherwise modify the details illustrated without prior notice.

1551 Mt. Rose Avenue, York, Pennsylvania 17403-2909 717.849.8100 Toll Free: 800/755-6274

0223 - S14.11

Web Site: www.grahamwindows.com

Fixed Offset - 4"
 15/16" IG
 Single Plane



Series: S1400H

Manufacturing Code: S1412

Drawing 1/2 Scale - For Custom Size Drawing Contact Graham

Note: Sealant Not Shown On Details. Refer To General Installation Instructions.

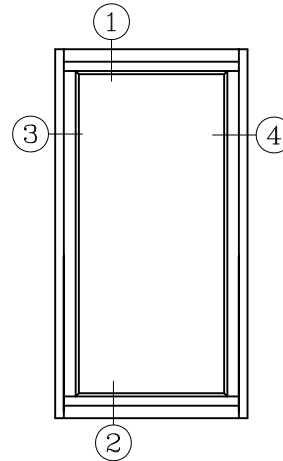
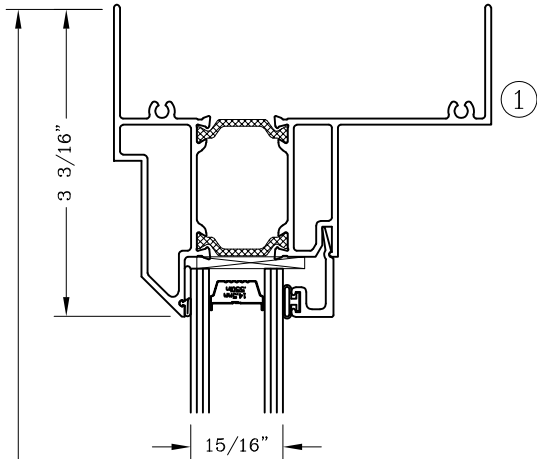

ELEVATION

Window Dimension

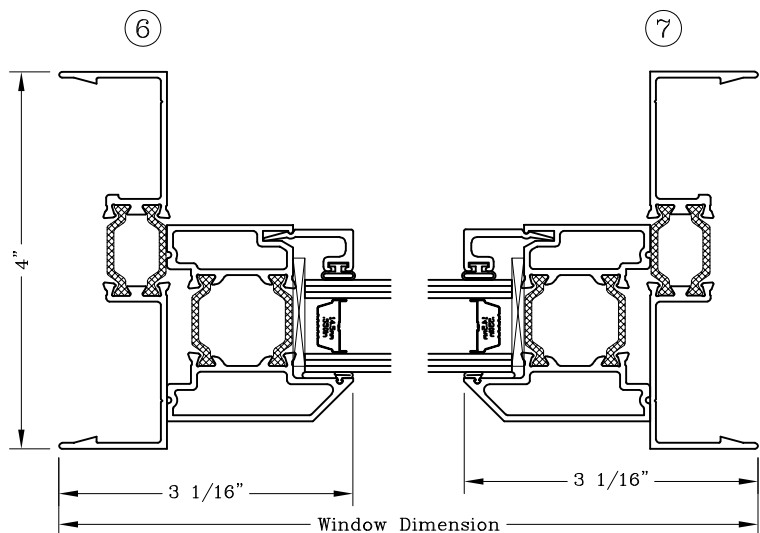
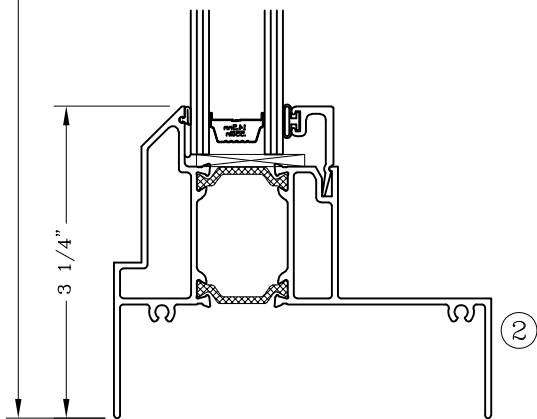

Graham Architectural Products reserves the right to change, add, cancel, remove or otherwise modify the details illustrated without prior notice.

1551 Mt. Rose Avenue, York, Pennsylvania 17403-2909 717.849.8100 Toll Free: 800/755-6274

0223 - S14.12

Web Site: www.grahamwindows.com