

S6300 Casement & Fixed Windows



1551 Mount Rose Avenue
York, PA 17403-2909

(717) 849-8100

Installation Guidelines for

**S6300 Casement and Fixed
Human Impact Window**

Approved 11/30/2022

S6300 Casement & Fixed Windows

Installation Guideline Disclaimer

This document contains general installation guidelines for Graham Architectural products and does not address each particular condition or installation. Shop drawing installation details may vary from these Guidelines as these Guidelines do not address each particular condition so any variances should be addressed by the design professional. These Guidelines do not address the structural adequacy on any installation and such should be addressed by a design professional. Anchorage to wall conditions must meet structural calculations, which are based on the product tested. Sealant compatibilities and application details should be reviewed by the sealant manufacturers. This document does not address the interface between the window system and the buildings weather barrier system which should be reviewed by the waterproofing consultant. It is generally recommended that insulation be installed in all voids created in the installation of a thermally improved system, but the application of insulation in wet areas needs to be addressed by the design professional and the particular type of insulation may need to be specified.

S6300 Casement & Fixed Windows

These instructions include the installation and initial adjustment instructions of the S6300 windows. Read these instructions before starting any installation.

Receiving, Handling, and Storage

The proper receiving, handling and storage of windows and doors is critical to the performance of the products throughout their service life. Abuse of the products during these processes will affect their operation and appearance. Even if the effects are not immediately noticed, they could surface later in the life of the product. The following are precautions that need to be followed.

Receiving: Prior to receiving the shipment of the windows, ensure that there is an adequate location to receive the windows and enough manpower and equipment to off load the products.

- Depending on the glass configuration and the size of the windows, the windows may be extremely heavy. A loading dock or glass manipulator may be needed to offload the windows without damaging them. Contact Graham Architectural to determine the weight of any windows that are over 22 square feet.
- Most trucking companies allow a 3 hour off-loading time, and will charge a detention fee if the truck is not off-loaded within that time period. That should be considered when determining the location where the truck will be off-loaded and how much manpower will be needed to complete the process.
- Ensure that the storage location is close to the off-loading area. The product storage area must meet the requirements listed in the “Storage” section below.

Handling: HANDLE CAREFULLY – DO NOT DROP.

- It's recommended to use a glass manipulator for large or heavy units. Ensure that there is enough manpower to lift and maneuver the windows. Use glass cups when possible. Only use material handling equipment that will not damage the finish of the products.
- Be careful when handling windows. Make sure the vent(s) and panel(s) are fully locked prior to moving windows. Never have fingers or hands inside the operating area of a vent or panel.
- Do not use any of the hardware or grids for lifting or manipulating the window. Glazed products must always be transported vertically.

Storage:

- The storage location for any finished products must be cordoned off to prevent damage from other trades, such as moving equipment.
- Stack vertically and on their sills with adequate separation so window parts (including hardware) will not rub together, including any protruding hardware such as handles. All products should be stored on top of wood blocking to protect the finish and weather-strip. Blocking will also be needed between the frame and any object that can damage the window frame.

S6300 Casement & Fixed Windows

- Ensure that the products cannot be blown over by the wind and limited to stacking of five (5) units before alternate support is given. If the windows are going to be stored for a short period of time (less than 1 month), they can be leaned at a 15° – 20° angle from vertical, with blocking to prevent them from rubbing/deforming. If they are going to be stored for an extended period of time, they will need stacked vertically (<3° from vertical) with strapping to prevent them from being blown over by the wind.
- Protect windows completely from moisture and dirt prior to installation. It is important that all windows that are not installed, are protected from direct contact with rain, snow, or ice so as to protect the finish and glazing of the product. If water gets into, and is retained in the glazing pocket it will cause the edge seal of the insulating glass to fail.
- Storing the windows in the building is preferred, as long as they are not in a high traffic area. If stored in a trailer, or under clear plastic, there must be adequate ventilation to prevent the temperature of the products from exceeding 110° F (43.3° C). Temperatures exceeding this threshold can damage the sealants in the insulating glass. Heat build can also cause stress fractures in the glass. If storing outside, the products must be covered in a manner that will prevent water from getting into the products, while allowing ventilation to prevent excessive temperature or humidity build-up.
- Construction debris and dirt within the frame will affect the operation of the window. Protect all products from paint, weld spatter, construction debris, cement, plaster, terrazzo, and other construction materials, which include, but are not limited to, alkali based materials or caustic cleaners. This must be removed immediately to prevent damage to the finish of the aluminum or to the clarity of the glass.
- If the windows have been wrapped in a transparent plastic protective wrap, this wrap cannot be on the product for more than 90 days from the date of manufacturing, otherwise, it will be very difficult to remove protective wrap from the window finish.
- Prior to applying sealants, the surfaces must be cleaned and prepared as directed by the sealant manufacturer.

CAUTION – Windows are not to be used as ladders, scaffolds, or supports. Installed window openings are not to be used as construction entrances, unless adequate protection to the window sill and jambs is provided. Damage to any products from any construction activity will void the product warranty for the products in question.

Note: Copies of these instructions can be downloaded from www.grahamwindows.com/architectural-resources/technical-information/

S6300 Casement & Fixed Windows

General Installation Instructions

A. Upon delivery carefully check that all windows have been received undamaged. If any of the windows have been damaged, immediately notify your Graham Representative.

B. The sill will need adequate support. The sill must be level in accordance with Table #1.

Table #1	Installation Tolerances (+/- Target)		
	Inches/ foot	Inches Maximum	Method of Measurement
Level (Horizontal Measurement)	1/32"	1/8"	Measure sill using level
Plumb (Vertical Measurement)	1/32"	1/8"	Measure jambs using level or plumb bob
True (In Plane Measurement)	1/32"	1/8"	Attach strings across corners. Measure where they cross
Extrusion Straightness	1/64"	1/16"	Measure with straight edge.
Square (Diagonal Measurement)	N/A	1/16"	Measure diagonal corners (Difference/2)
*Casements have a tight tolerance to ensure proper operation			

C. All work should start from established bench marks and column center lines established by the architectural drawings and the general contractor.

D. The sequence of installation should be coordinated with the job superintendent so delays are prevented.

F. Be aware of allowable edge distance requirements for the fasteners into the substrate, especially when the substrate is masonry. Refer to the fastener manufacturer's instruction for proper usage.

G. Seal the exterior in accordance with the shop drawings.

H. Insulate between the window frame and the rough opening.

I. If the windows are to be installed using panning, refer to the Graham Installation Guidelines for the type of panning being used. www.grahamwindows.com/architectural-resources/technical-information/. However, trim and clip cannot be used to attach the window to the opening. Only strap anchors can be used on the S6300 windows.

Note: Panning cannot support the weight of a window without proper blocking/shimming.

S6300 Casement & Fixed Windows

J. In order to meet the Human Impact requirements, the S6300 windows must be installed using strap anchors. Heads of the 1/4"-20 machine bolts are inserted into a slot at the end of the track, and then are slid to the proper location for attachment to the strap anchors with the supplied nut with flat and lock washer (See Figure #2).

K. Attach the strap anchors to the building structure using the fasteners approved for the specific project. The fastener type will depend on the substrate. Fasteners must be installed as specified in the structural calculations. If there is no specified fastener spacing, attach the fasteners 6" from each corner and a maximum of 12" on center. Install the fastener through the strap anchor at the end of the slot closest to the window.

L. For casement windows, install cross-blocking (shims) to prevent the casement from racking out of square when opened.

M. Install backer rod and sealant on the exterior perimeter (See Figure #2).

N. Check the window for square and proper operation. Adjust as necessary.

O. If a mullion is needed, Graham can supply a steel mullion (See Figure #3). The mullion will need attached to the opening with slotted angles, in accordance with engineering calculations. Then the strap anchors are attached to the steel mullion.

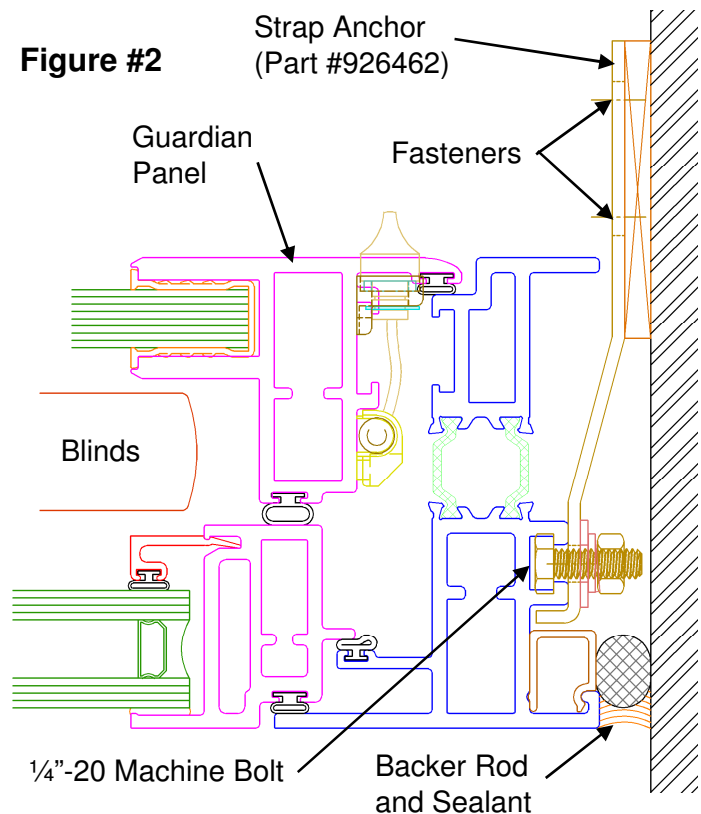
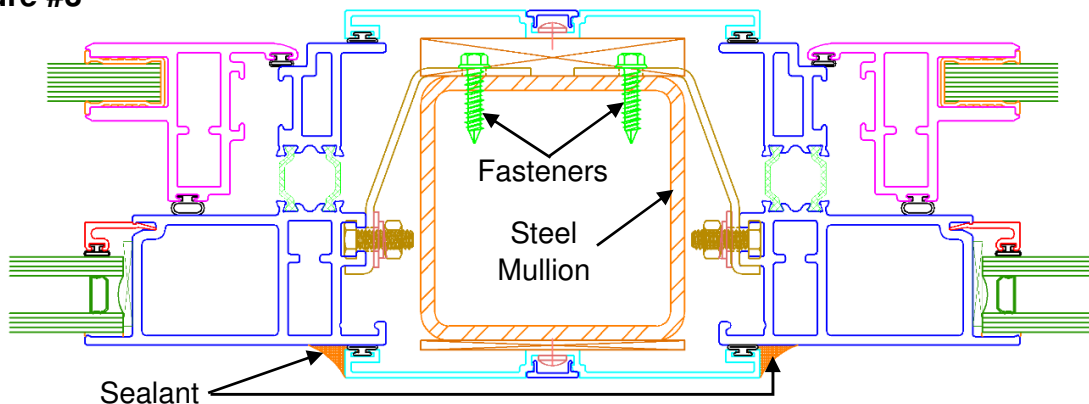

Figure #3



S6300 Casement & Fixed Windows

Curtain Wall Inserts (or Overlays) Installation

- A. In order to meet the Human Impact requirements, the S6300 Insert or Overlay Panels must be installed using the fasteners dictated by the engineering calculations. Whatever fastener is used, the fastener head cannot interfere with the Guardian panel operation.
- B. If there is no specified fastener spacing, attach the fasteners through the frame 6" from each corner and a maximum of 12" on center (See Figures #4 and #5).
- C. Check the window for square and proper operation. Adjust as necessary.

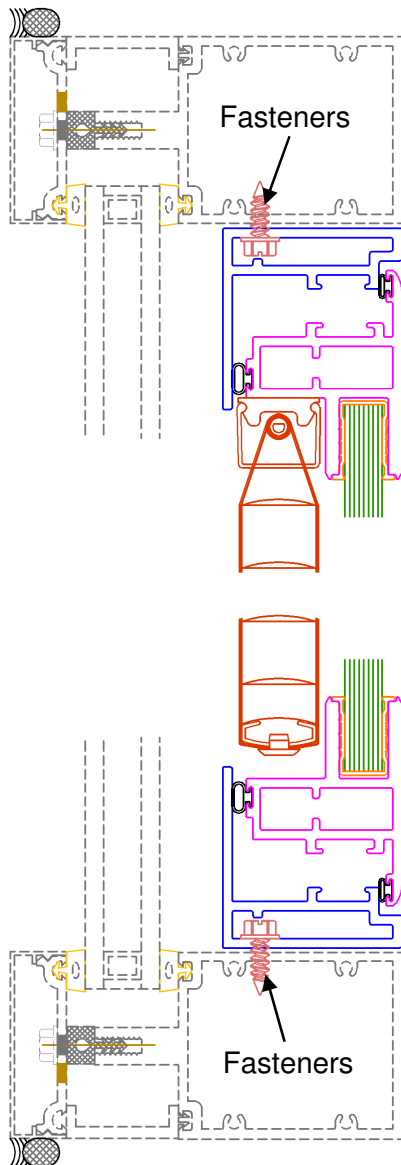

Figure #4

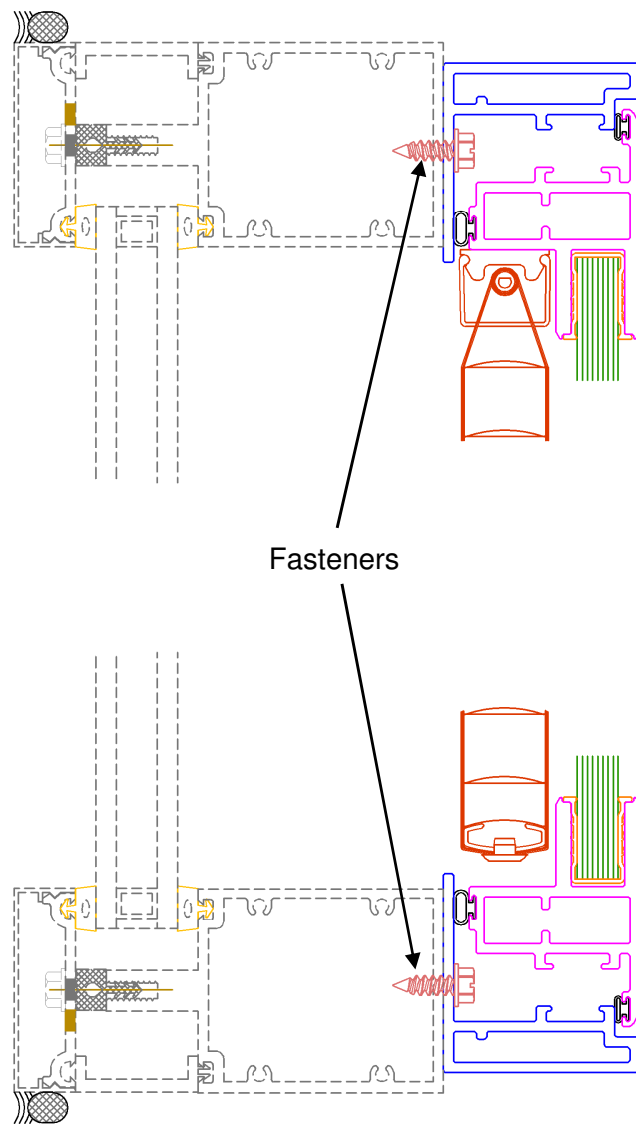

Figure #5

S6300 Casement & Fixed Windows

Operation:

To open the primary vent:

1. Insert the GEM key into the lock housing. Turn the key ¼ turn to disengage the lock (See Figure #6).
2. Use the “T” shaped keys (one per keeper) to unlock each of the keyed actuators (See Figure #7).
3. Using the “T” shaped keys as handles pull the vent or panel inward to open.

For casement windows to access the interior space between the main glazing and the access panel glazing (blinds):

4. Once the main vent is opened, locate secondary vent locks located along vent lock rail.
5. Use hex key to loosen hex screw on each of the secondary locks (See Figure #8).
6. The access panel can now be hinged open away from the main frame to access the blinds.

Mini-blind adjustment:

1. The mini-blinds are secured in the retracted position with zip-ties for shipping purposes (See Picture #9). Cut the zip ties and lower the blinds prior to operating.
2. Check the operation of the blinds. The mini blinds are tilt operated by a Tilt Control Knob located on the interior face of the vent rail or removable hex key (See Figures #10 & #11).



Figure #6



Figure #7

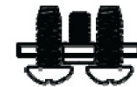
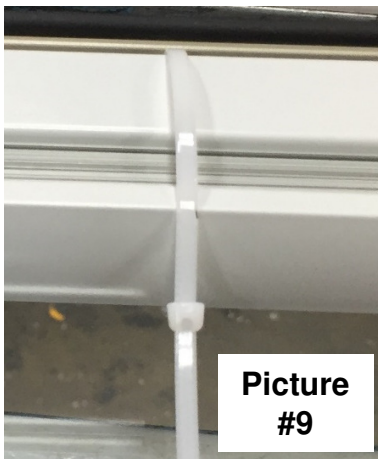
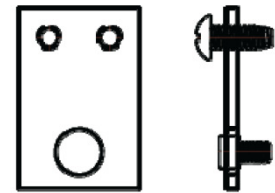

Figure #8



Picture #9

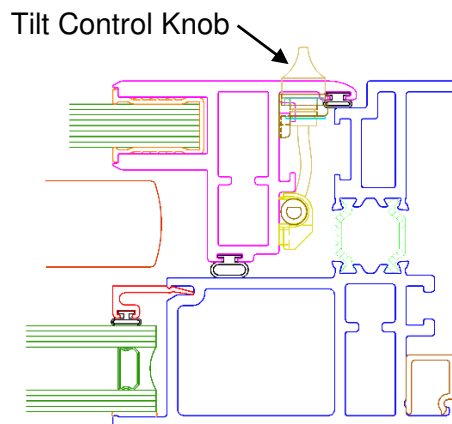
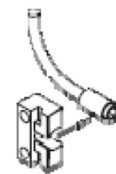

Figure #10



Concealed Removable Key Operator (1/8" or 3/16" Hex)

Figure #11

S6300 Casement & Fixed Windows

Vent Lock Adjustment:

The lock keepers may need adjustment, in order to tighten the vent to the frame. Each locking bar will have two stainless steel studs that can be adjusted.

1. Open and close the primary vent as described above.
2. If the locks are difficult to engage, the locks will need to be loosened (Go to step #4).
3. Compression of the weatherstrip can be checked by inserting a piece of flexible paper (dollar bill) between the vent and the frame, and closing and locking the window. If the paper pulls out easily, the locks will need to be tightened
4. Open the vent to locate locking studs on the multi-point locking bar (See Figure #12).
5. Use 3/16" hex key to turn each stud left or right. The stud is an off-set cam that will tighten the compression of the vent when the line on the cam is turned toward the interior or loosen when it's turned toward the exterior (See Figure #13).
6. Recheck the compression of the weatherstrip in step #3.

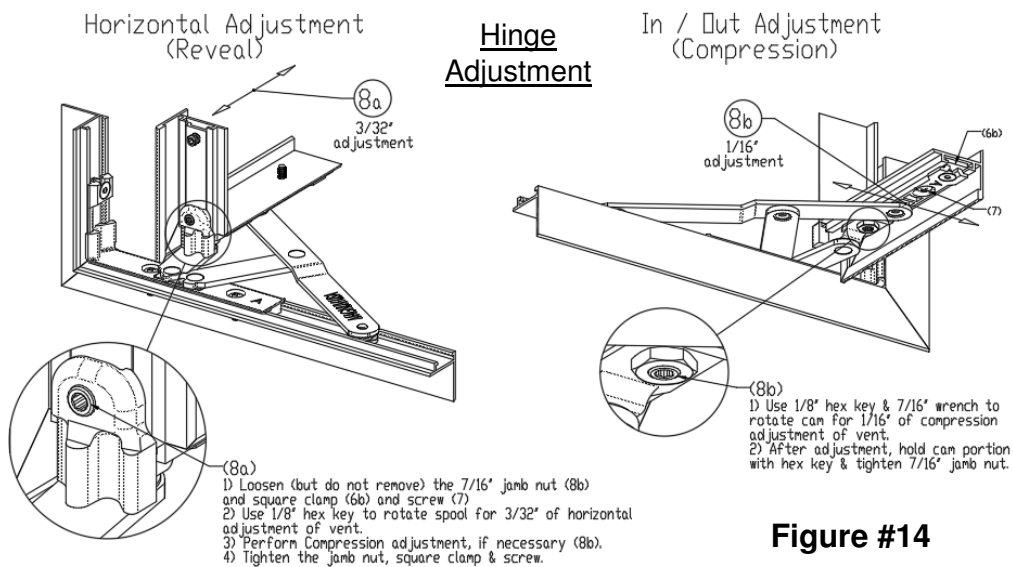
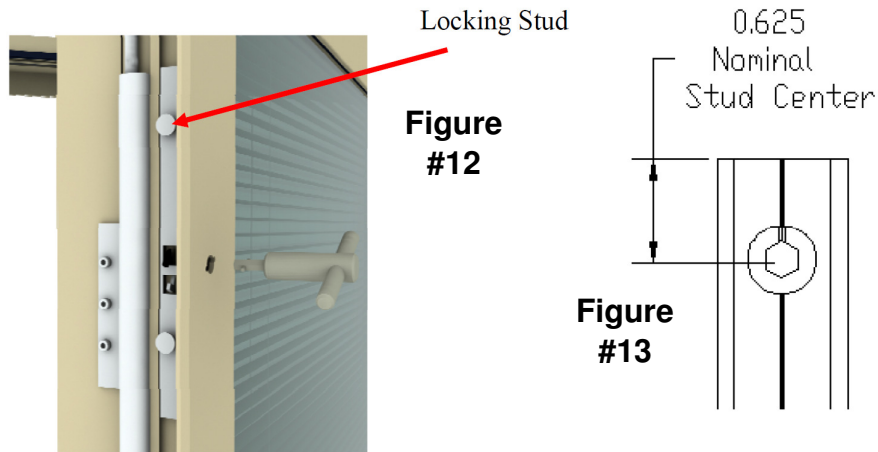

S6300 Casement & Fixed Windows

Polycarbonate Glazing:

Polycarbonate sheet should be washed with a mild solution of soap and warm water, using a soft cloth or sponge. To prevent water spots, thoroughly dry with a chamois or sponge. Do not use abrasive cleaners or sharp instruments such as razor blades or scrapers that may gouge the surface. For graffiti removal, organic solvents, such as butyl cellosolve, kerosene, VM&P naphtha or mineral spirits, work very well. Denatured ethanol, and isopropyl alcohol are also excellent cleansing agents. It is important to rinse the surface thoroughly after cleaning with solvents.

Fresh paint splashes, grease and smeared glazing compounds can be removed easily before drying by rubbing lightly with a good grade of naphtha or isopropyl alcohol. Follow the alcohol rub with a mild detergent wash and warm water, and end with a thorough rinsing with clean water.

To minimize hairline scratches use a mild automobile polish. Three such products that tend to polish and fill scratches are Johnson Paste Wax, Novus Plastic Polish #1 and #2, and Mirror Glaze Plastic Polish (MG M10). It is suggested that a test be made on a sample of the polycarbonate with the product selected prior to polishing the entire project.

Products such as abrasive or highly alkaline cleaners, acetone, carbon tetrachloride, benzene or leaded gasoline should NOT be used, and the sheet should not be cleaned in hot sun or at high temperatures.