

Curtain Wall Overlay Panel Human Impact Window



Series: S6300

Manufacturing Code: S6315

Drawing 1/2 Scale – For Custom Size Drawing Contact Graham

Note: Sealant Not Shown On Details. Refer To General Installation Instructions.

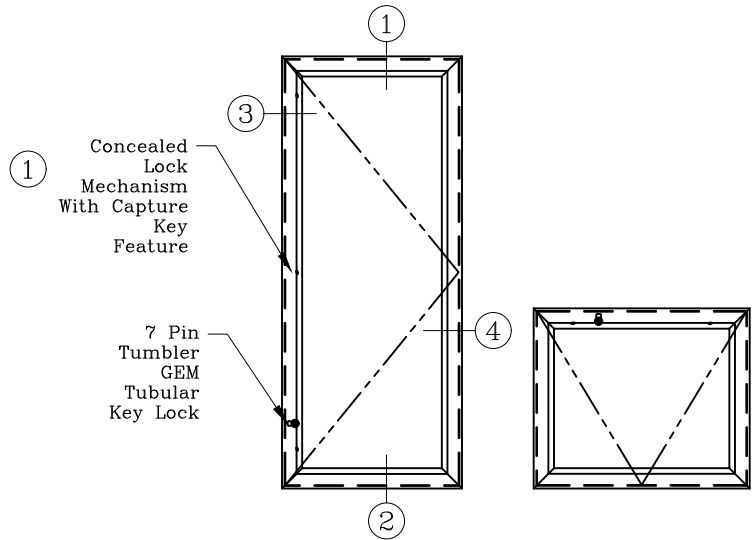
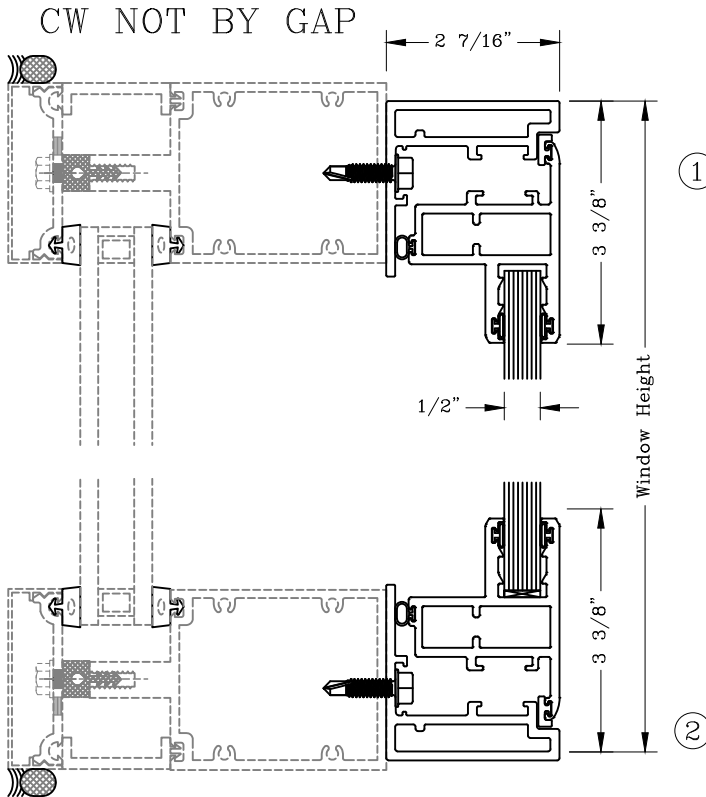

Elevations

Note: Phantom Line Represents Inswing Impact Panel Operation For Cleaning And Blind Access. Lines Converge At Hinge Side Of Panel.

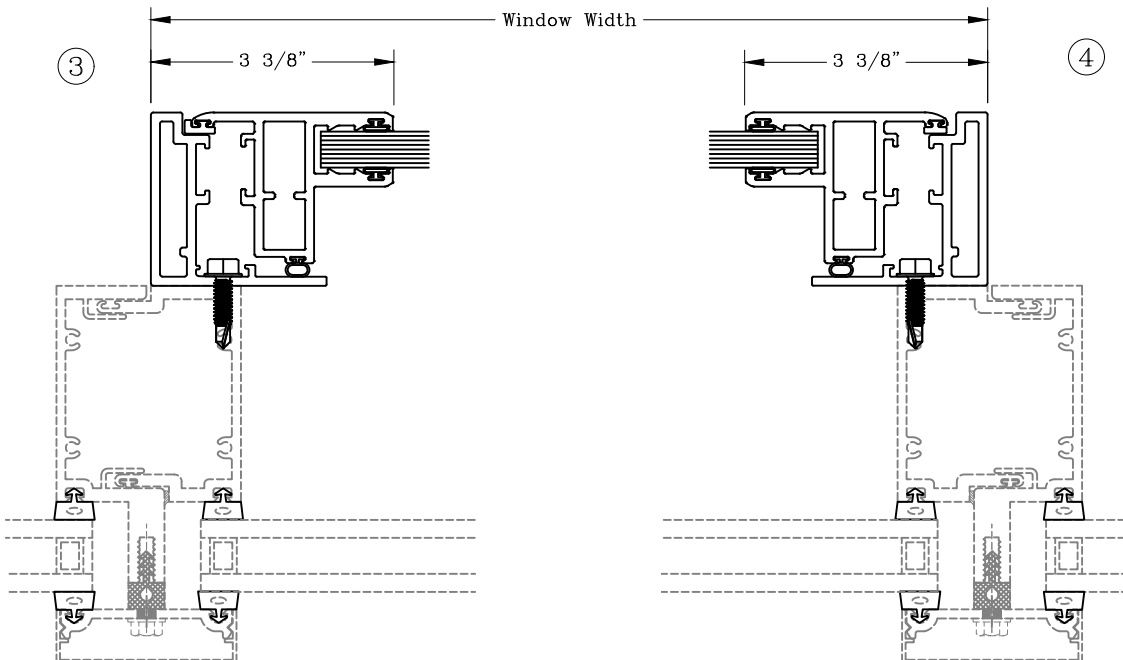

Graham Architectural Products reserves the right to change, add, cancel, remove or otherwise modify the details illustrated without prior notice.

1551 Mt. Rose Avenue, York, Pennsylvania 17403-2909 717.849.8100 Toll Free: 800/755-6274 0526 - S63.15

Web Site: www.grahamwindows.com