

# Installation Anchoring Human Impact Window



Series: S6300

Manufacturing Code:

Drawing 1/2 Scale – For Custom Size Drawing Contact Graham

Note: Sealant Not Shown On Details. Refer To General Installation Instructions.

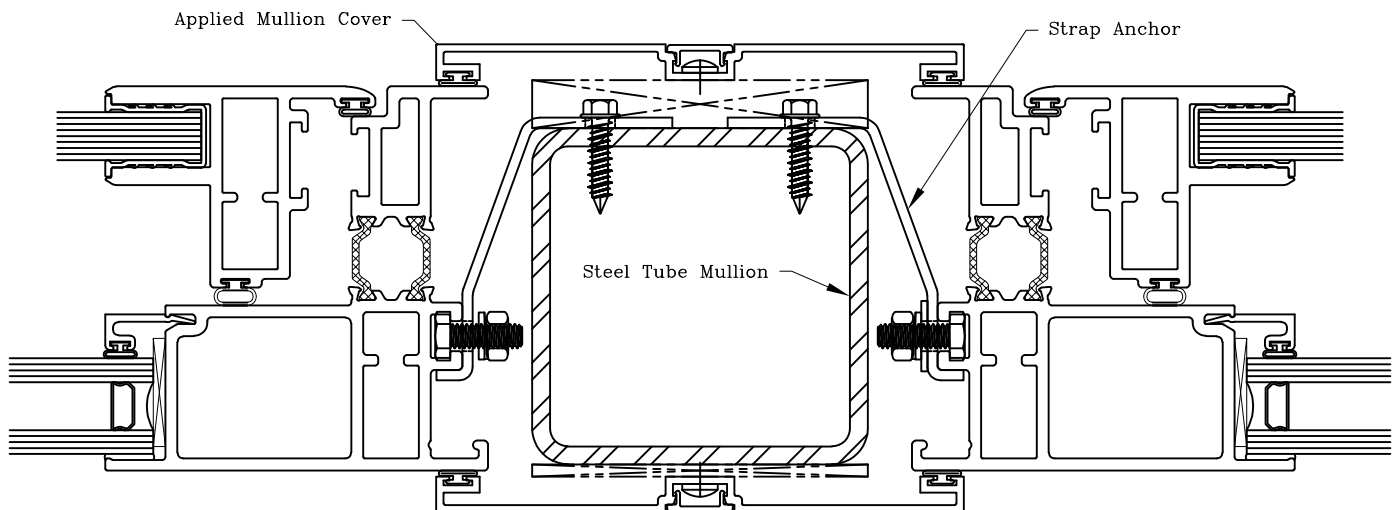
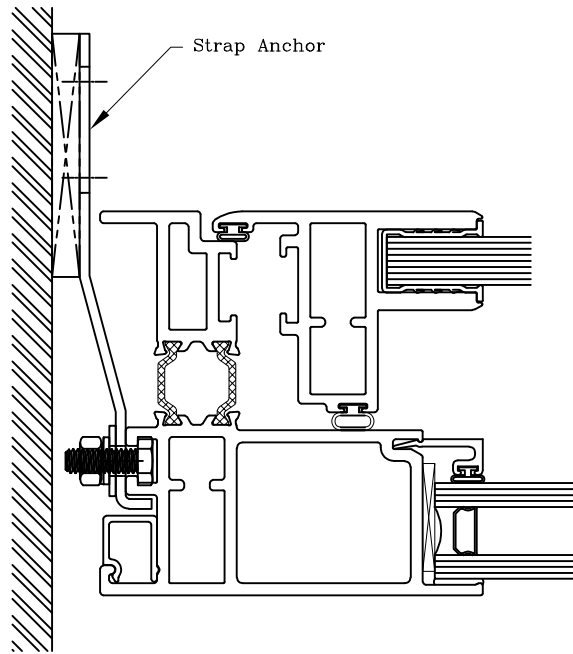

Details Shown Are For Concept Proposal Only  
Contact Graham Architectural Products For Job Specific Installation  
Anchoring Proposal Details Based On Building Conditions

Graham Architectural Products reserves the right to change, add, cancel, remove or otherwise modify the details illustrated without prior notice.

1551 Mt. Rose Avenue, York, Pennsylvania 17403-2909 717.849.8100 Toll Free: 800/755-6274

Web Site: [www.grahamwindows.com](http://www.grahamwindows.com)

0223 – S63.26